

Инструкция по сборке

Техас

Шкаф распашной №3

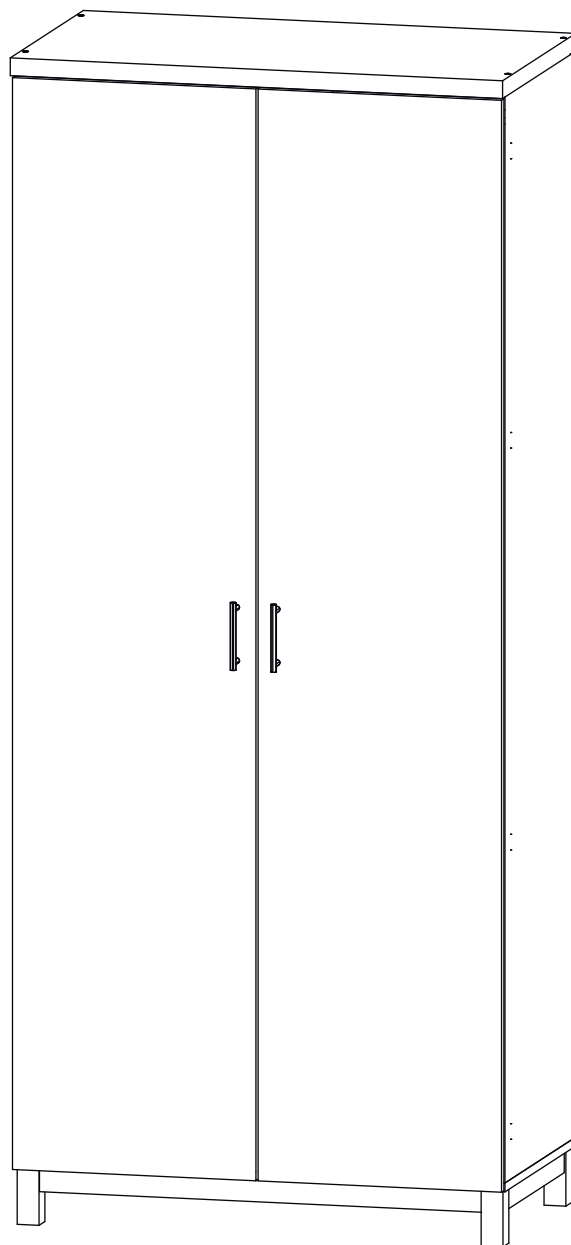



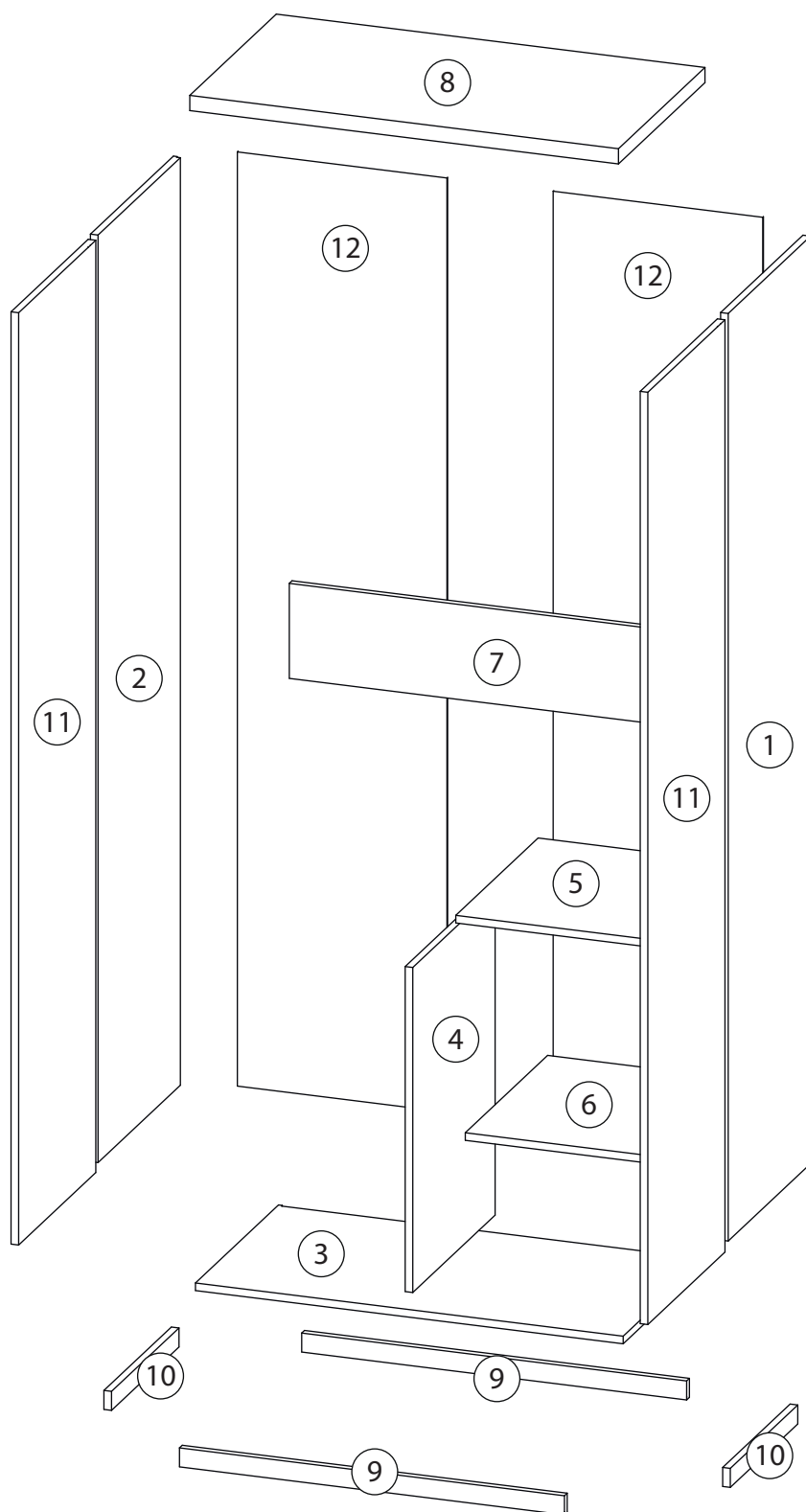

Детали

Поз.	Наименование	Кол-во	Длина	Ширина	Поз.	Наименование	Кол-во	Длина	Ширина
1	Бок правый	1	1952	480	7	Ребро жесткости	1	868	200
2	Бок левый	1	1952	480	8	Столешница	1	902	500
3	Дно	1	900	480	9	Планка	2	810	40
4	Вертикаль	1	684	476	10	Планка	2	390	40
5	Горизонталь	1	442	476	11	Фасад	2	1962	446
6	Полка	1	426	476	12	Задняя стенка	2	1966	441

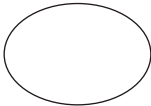
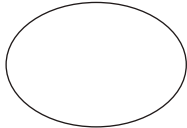
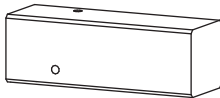
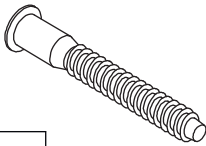
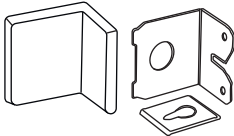

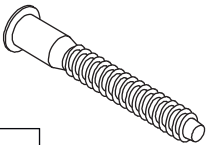
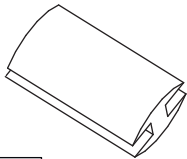
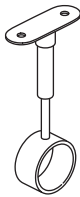
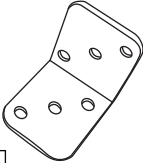
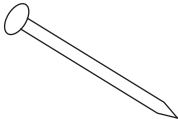
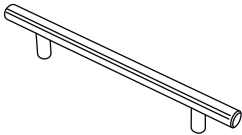
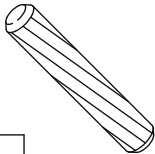
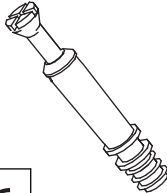
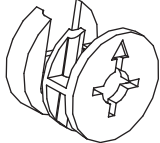
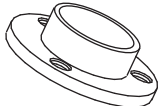
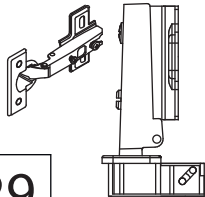
Фурнитура

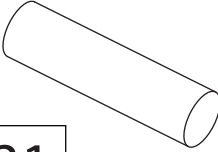
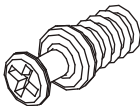
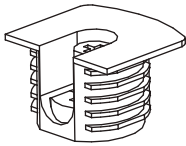
				
13	14	15	16	17
<u>Заглушка</u> Ø13	<u>Заглушка</u> Ø17-20	<u>Опора</u>	<u>Евровинт 7x50</u>	<u>Крепежный уголок</u>
				
18	19	20	21	22
<u>Саморез 3,5x16</u>	<u>Евровинт 7x70</u>	<u>Профиль для ДВП</u>	<u>Держатель трубы</u>	<u>Уголок</u>
				
23	24	25	26	27
<u>Гвоздь 1,6x25</u>	<u>Ручка</u>	<u>Шкант бук</u>	<u>Шток эксцентрика</u>	<u>Эксцентрик</u>
				
28	29	30	31	32
<u>Штангодержатель</u>	<u>Петля накладная</u>	<u>Евровинт 6,3x13</u>	<u>Штанга</u>	<u>Винт для стяжки</u> VB35
				
33				
<u>Стяжка VB35</u>				

1

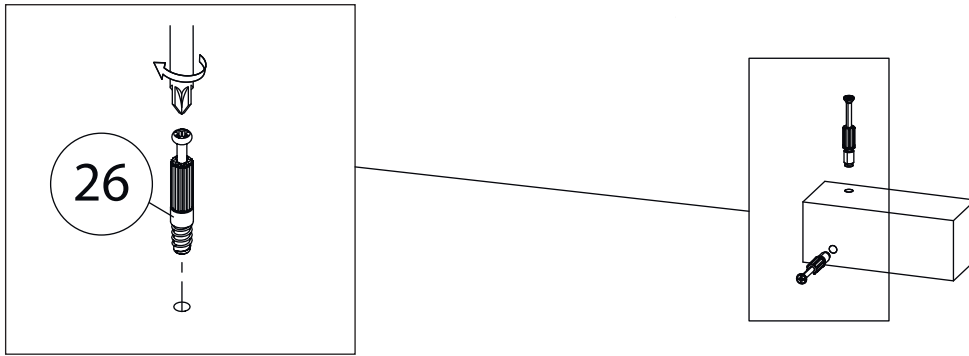

Остальные опоры
собирается аналогично.

2

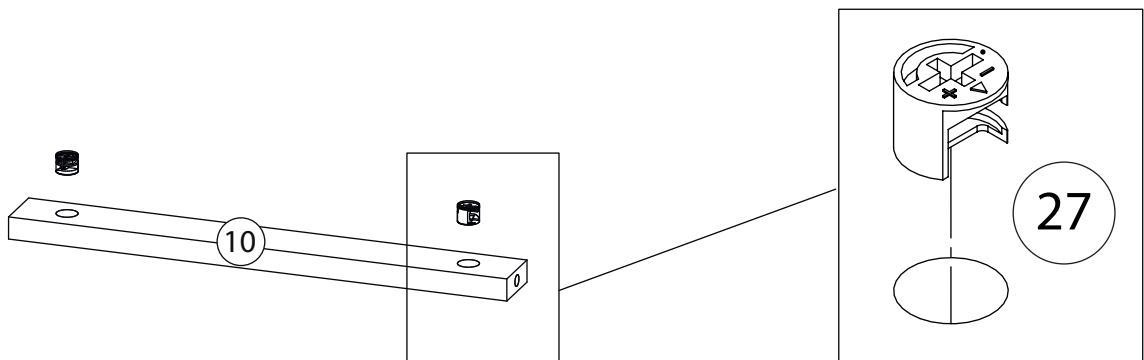

Планка (9)
собирается аналогично

3

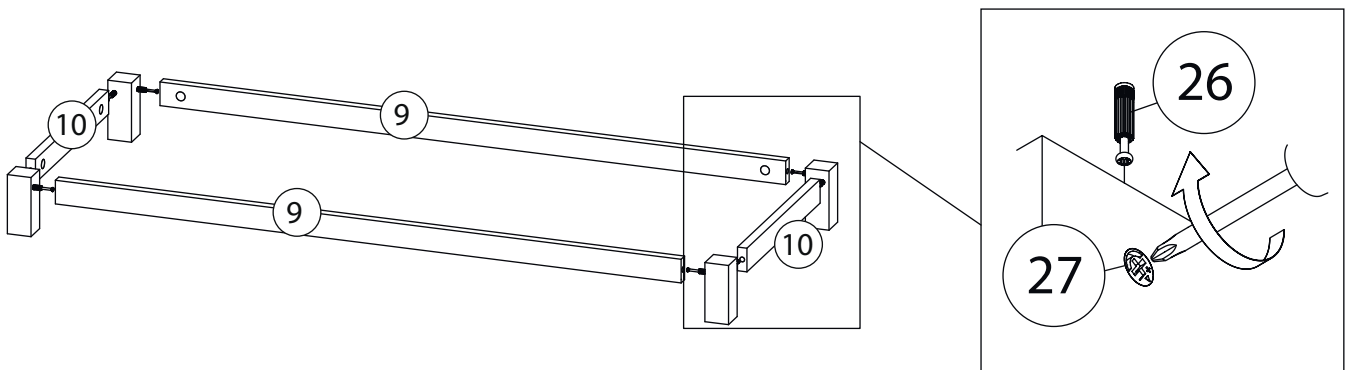

4

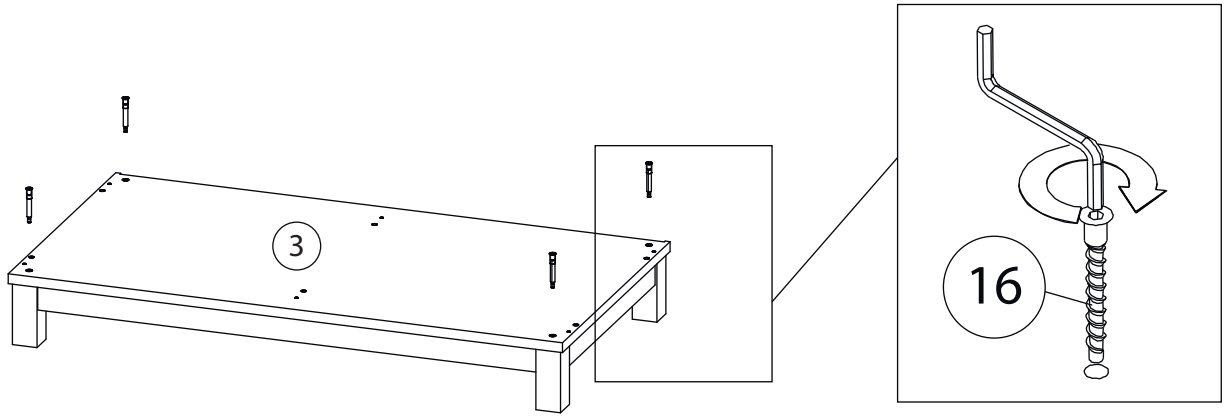

5

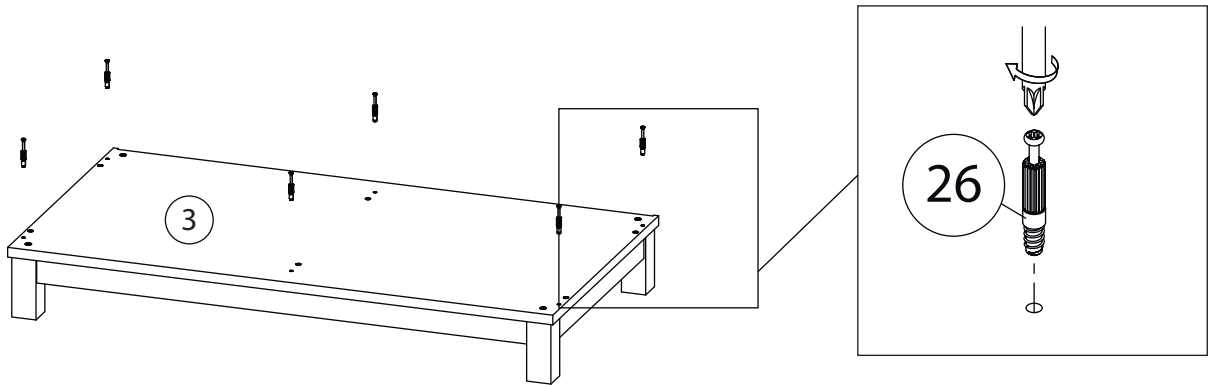

6

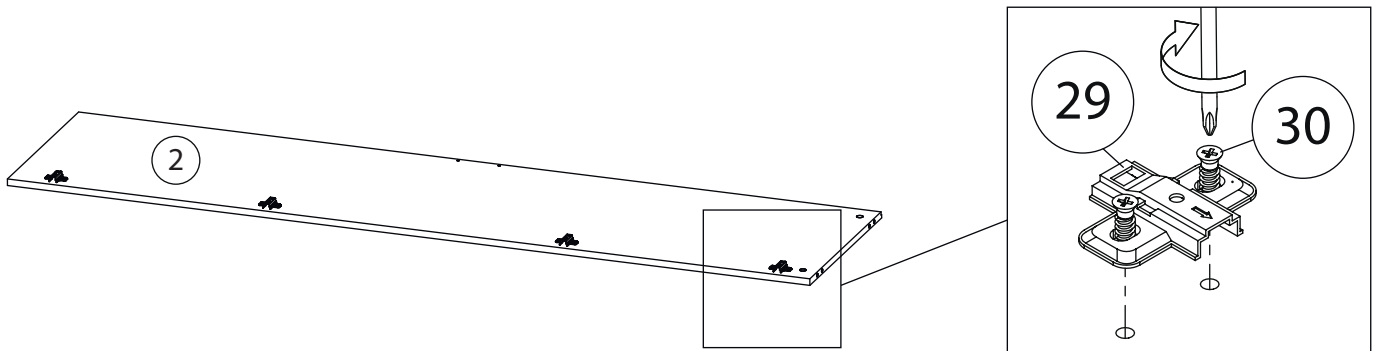

7

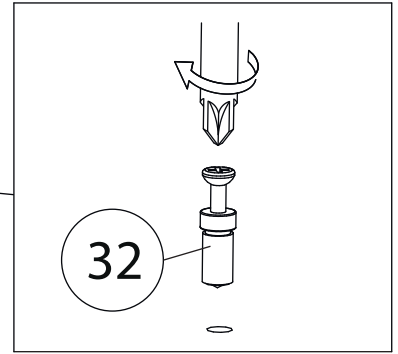
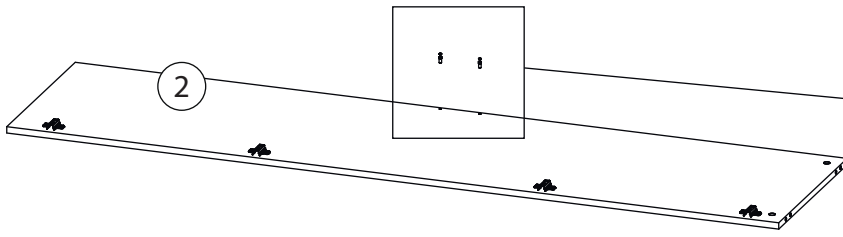

8

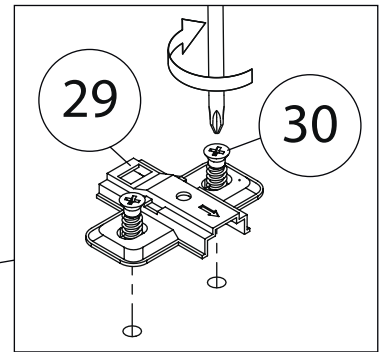
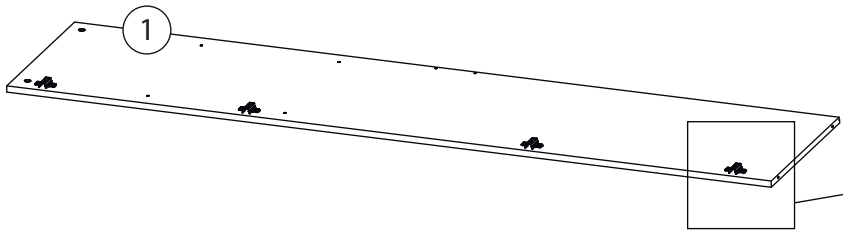

9

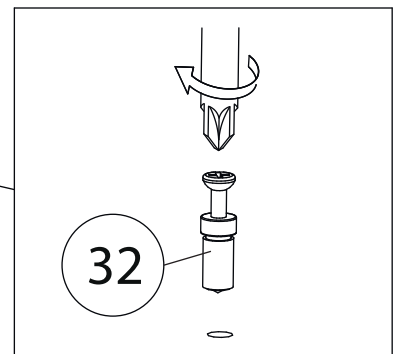
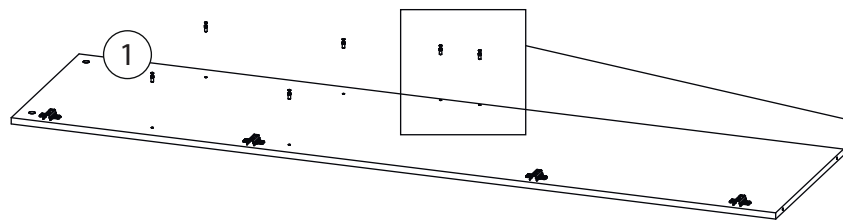

10

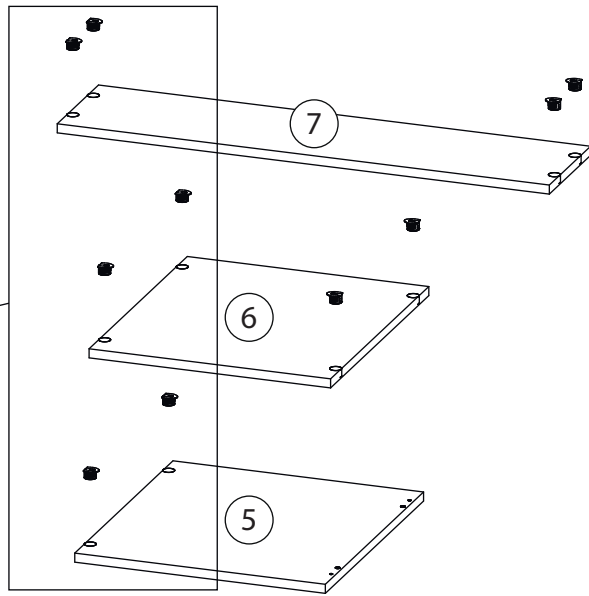
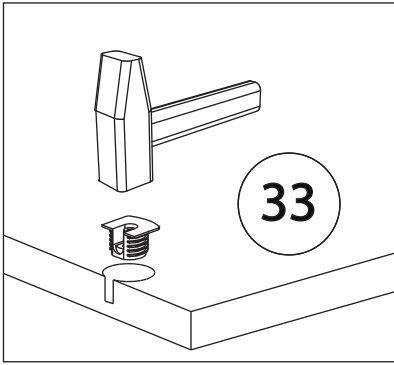

11

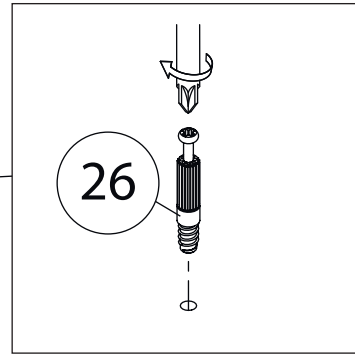
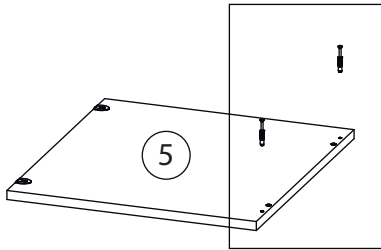

12

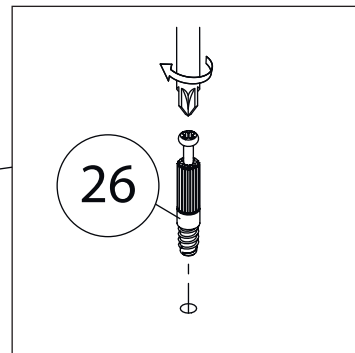
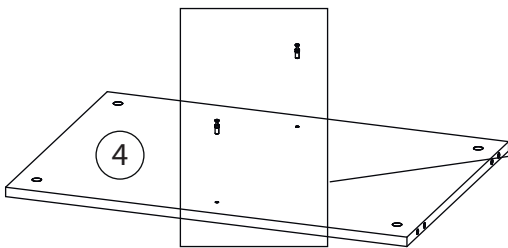

13

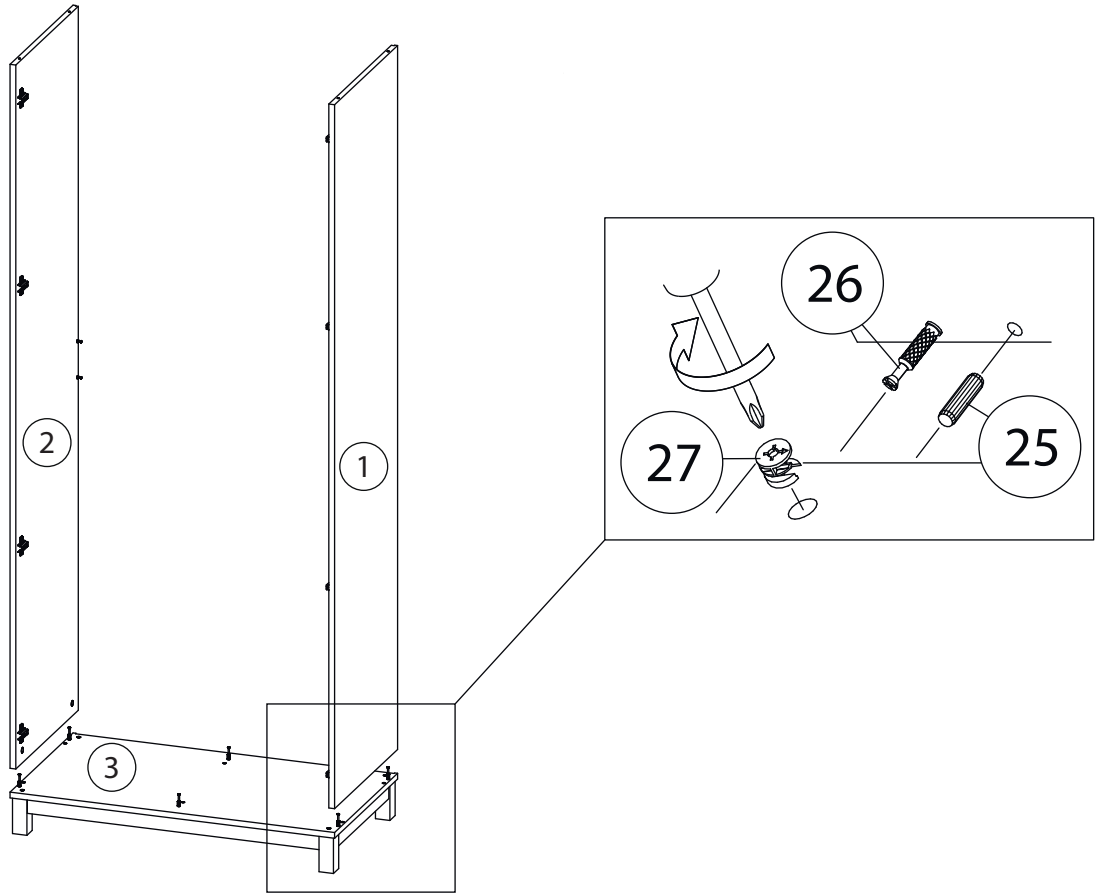

14

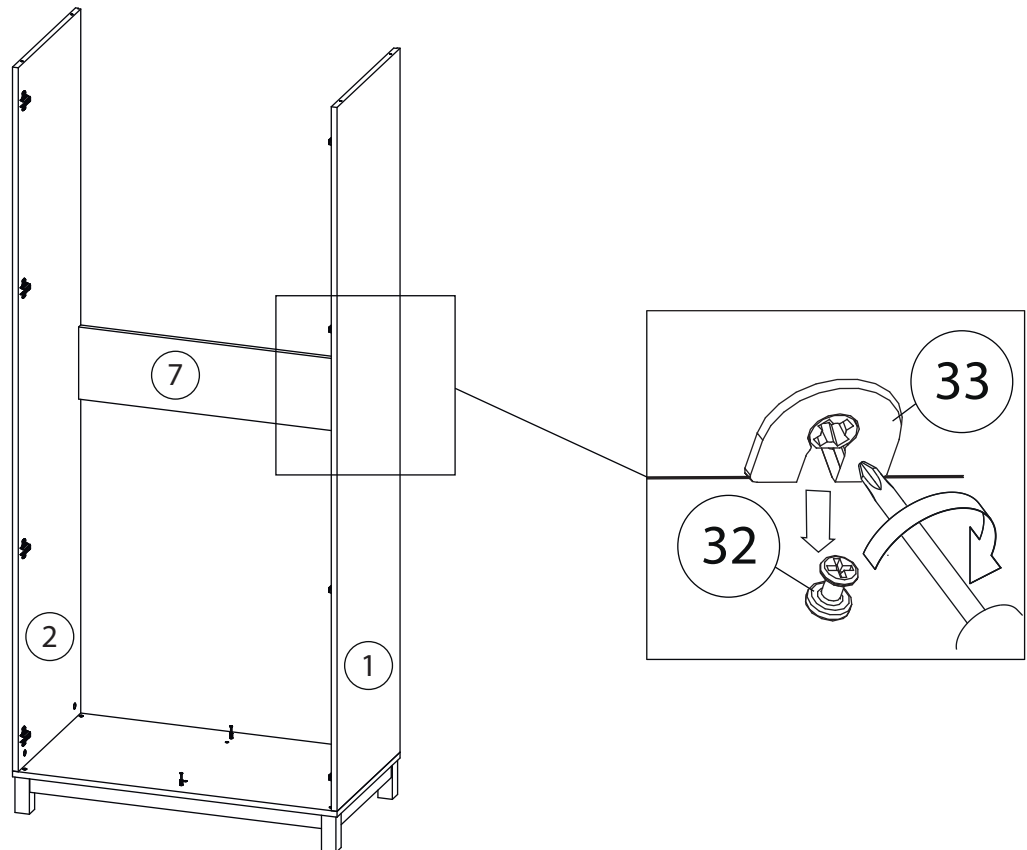

14

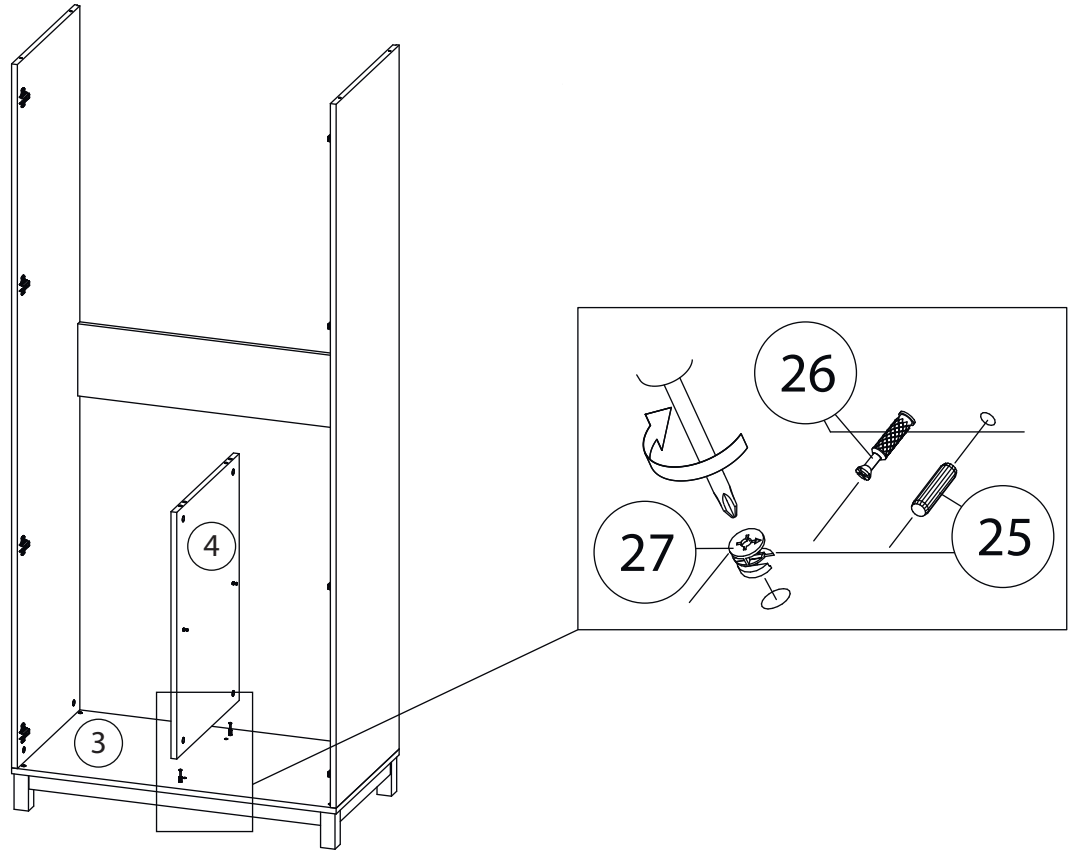

15

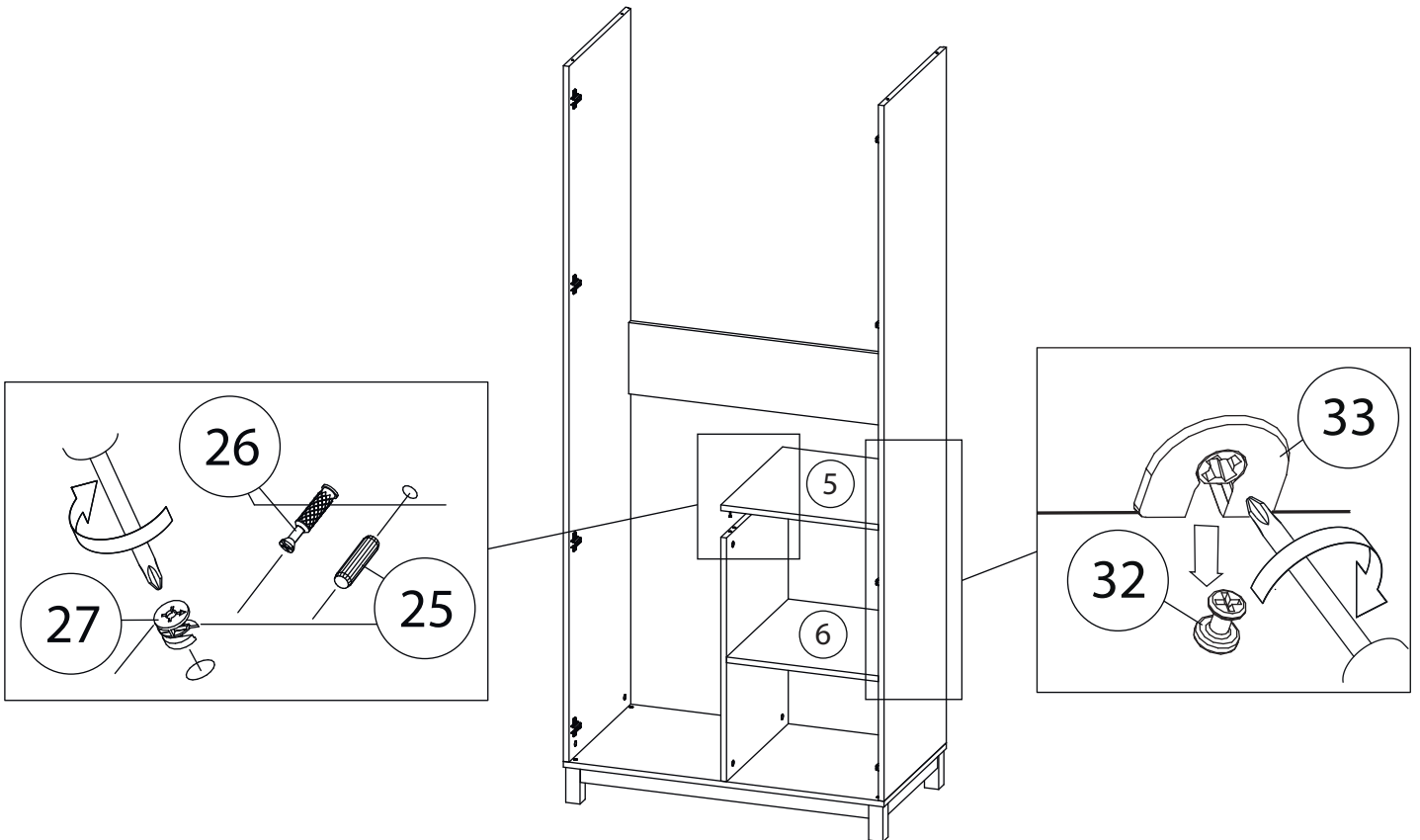

16

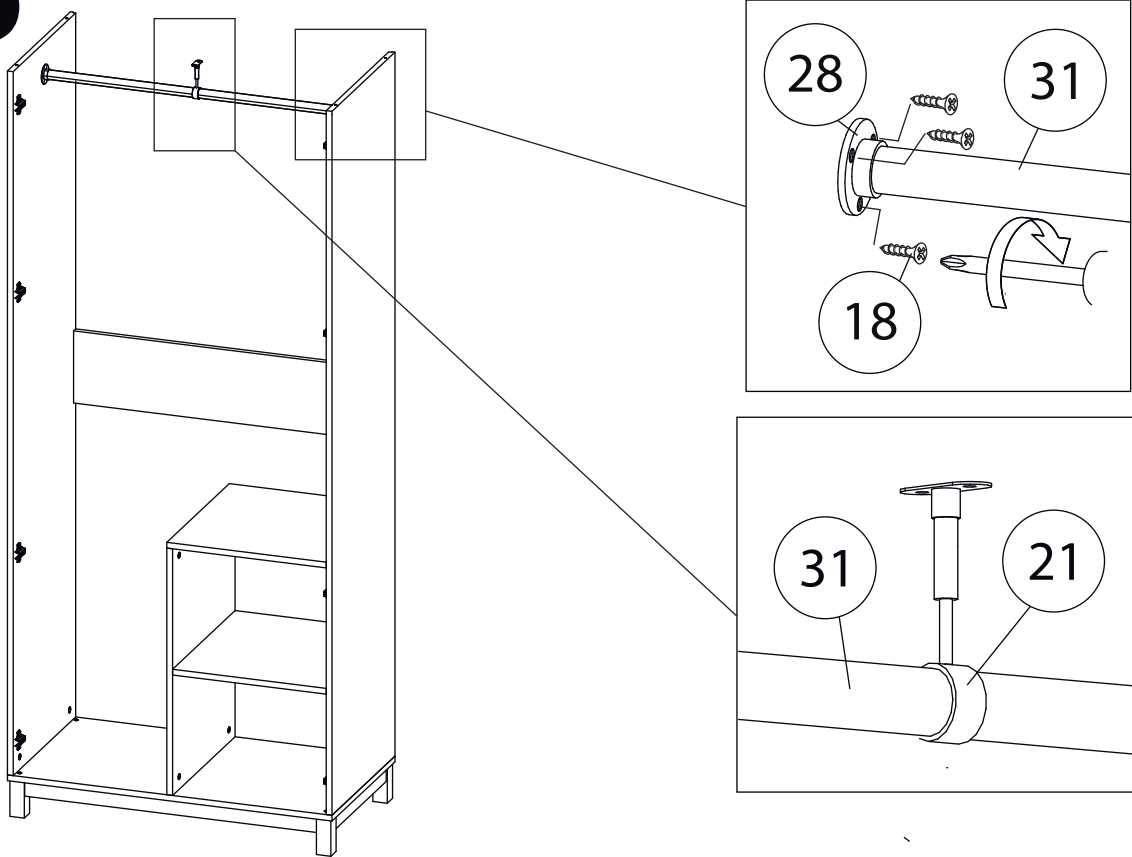

17

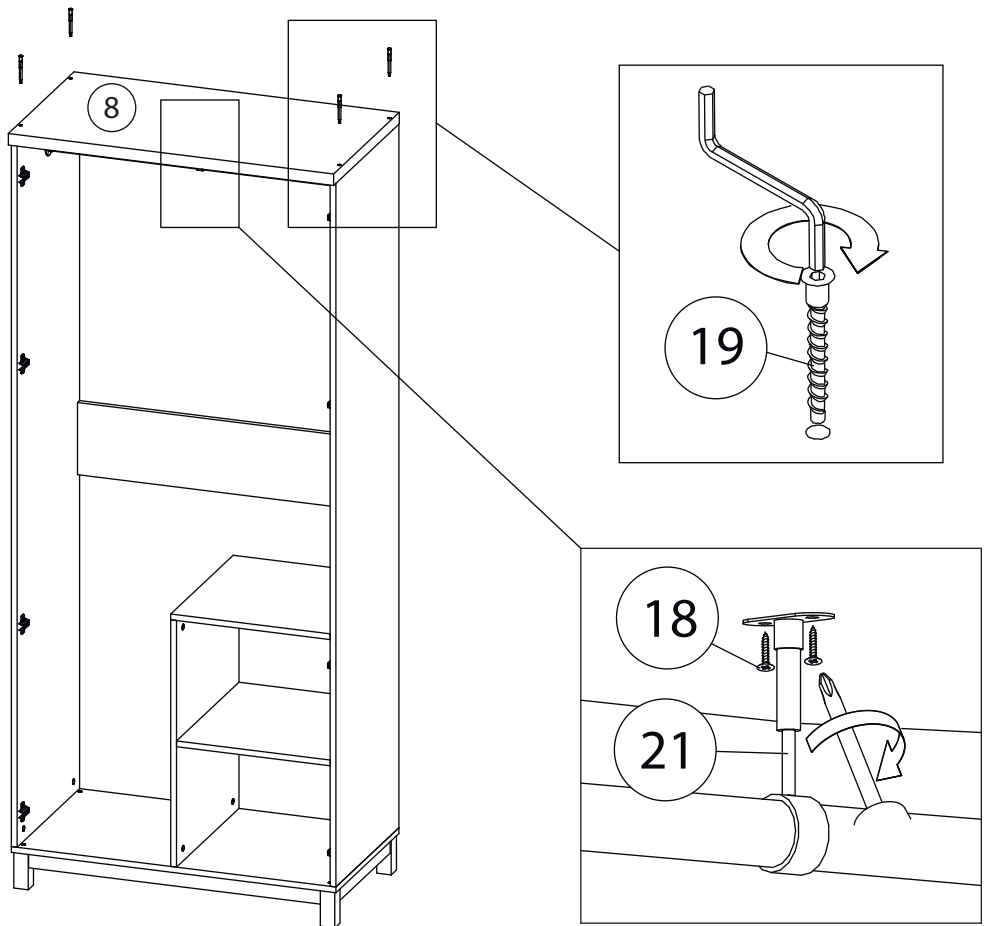

18

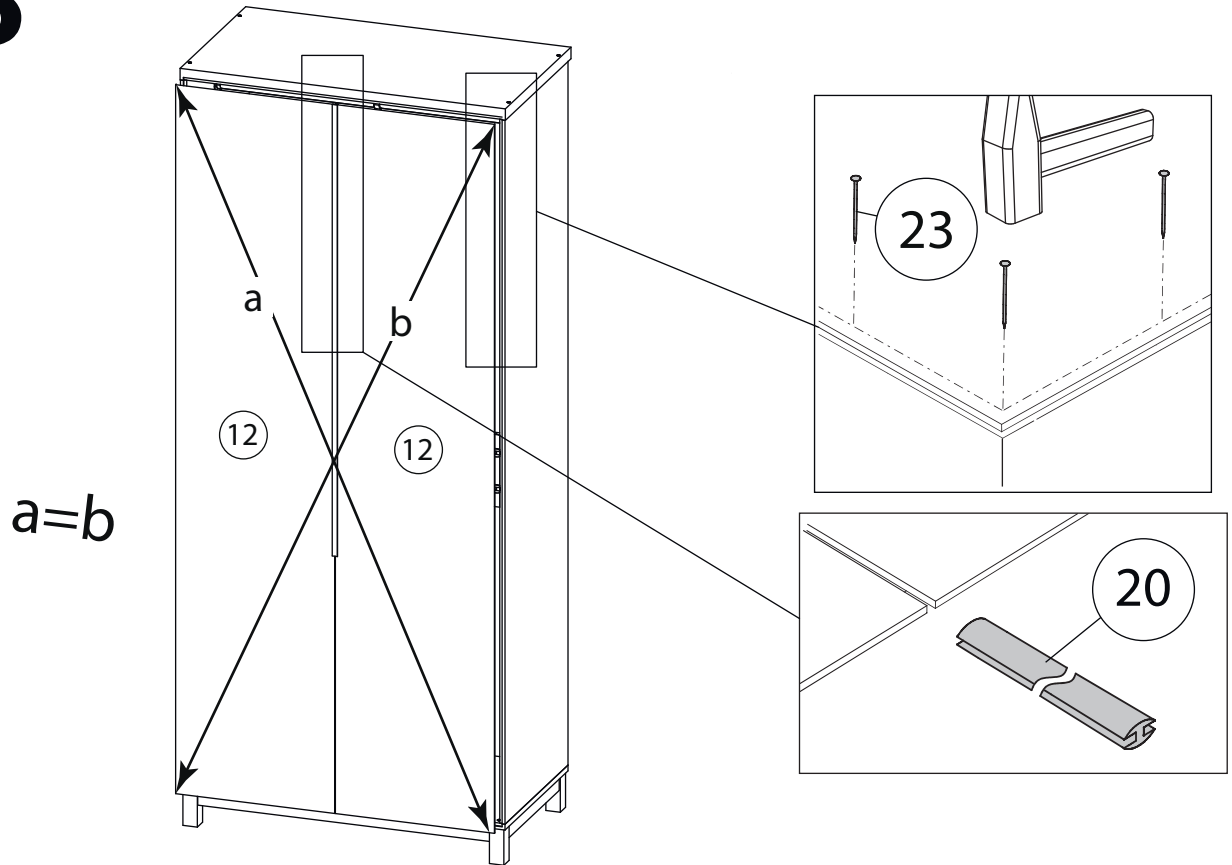

19

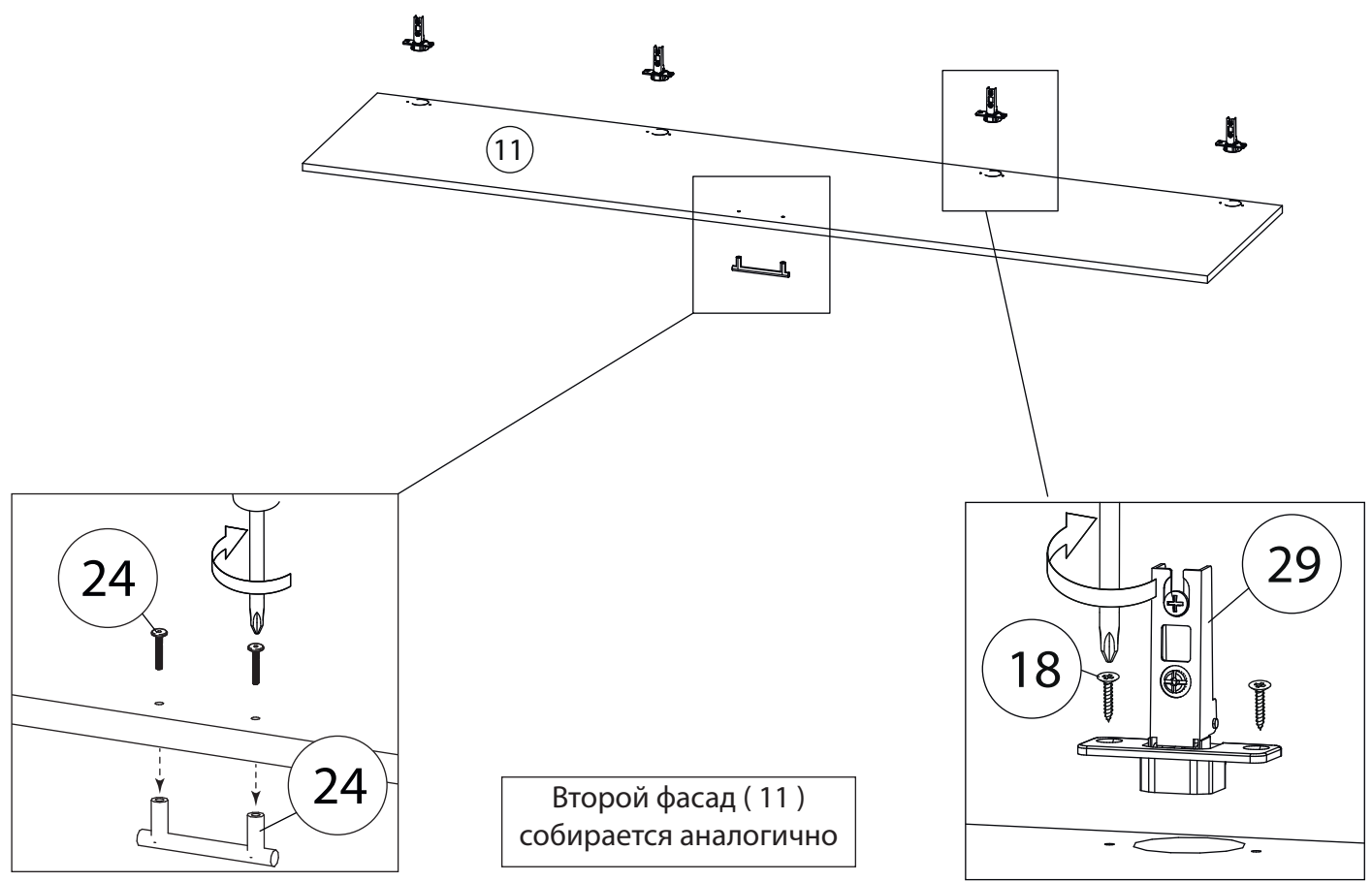

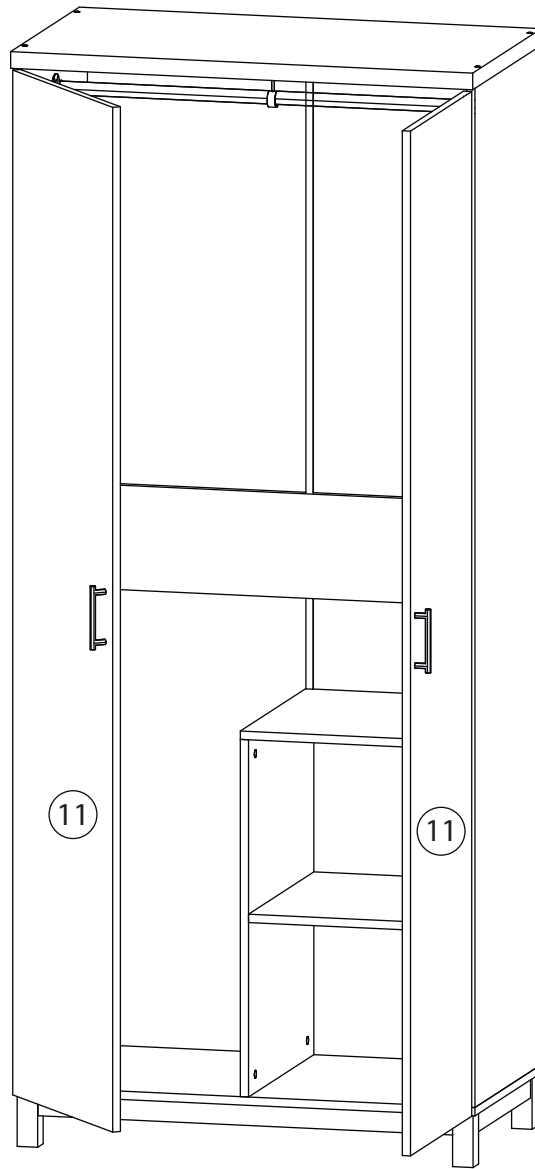

Заклеить технические отверстия заглушками.

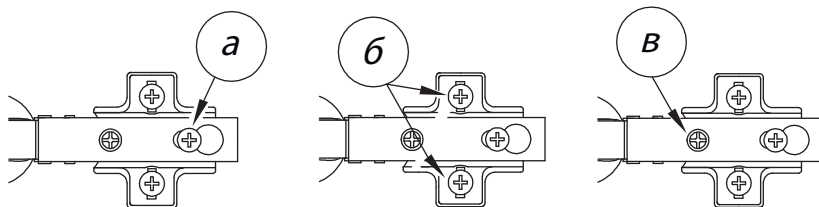

Регулировка петель

а - регулировка расстояния между дверью и корпусом
 б - регулировка положения двери по-вертикали
 в - регулировка положения ТТдвери по-горизонтали