

Инструкция по сборке

Непи

Витрина

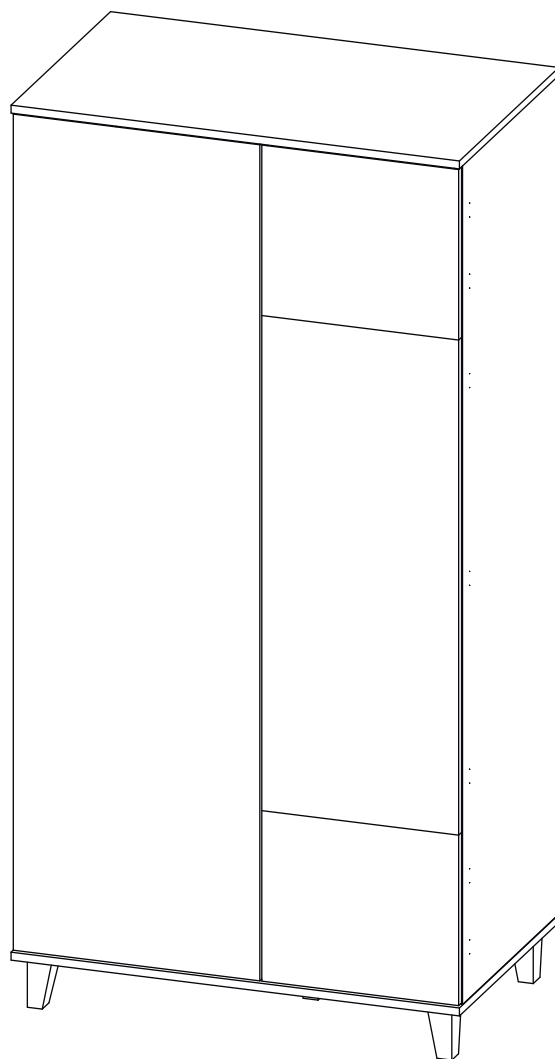



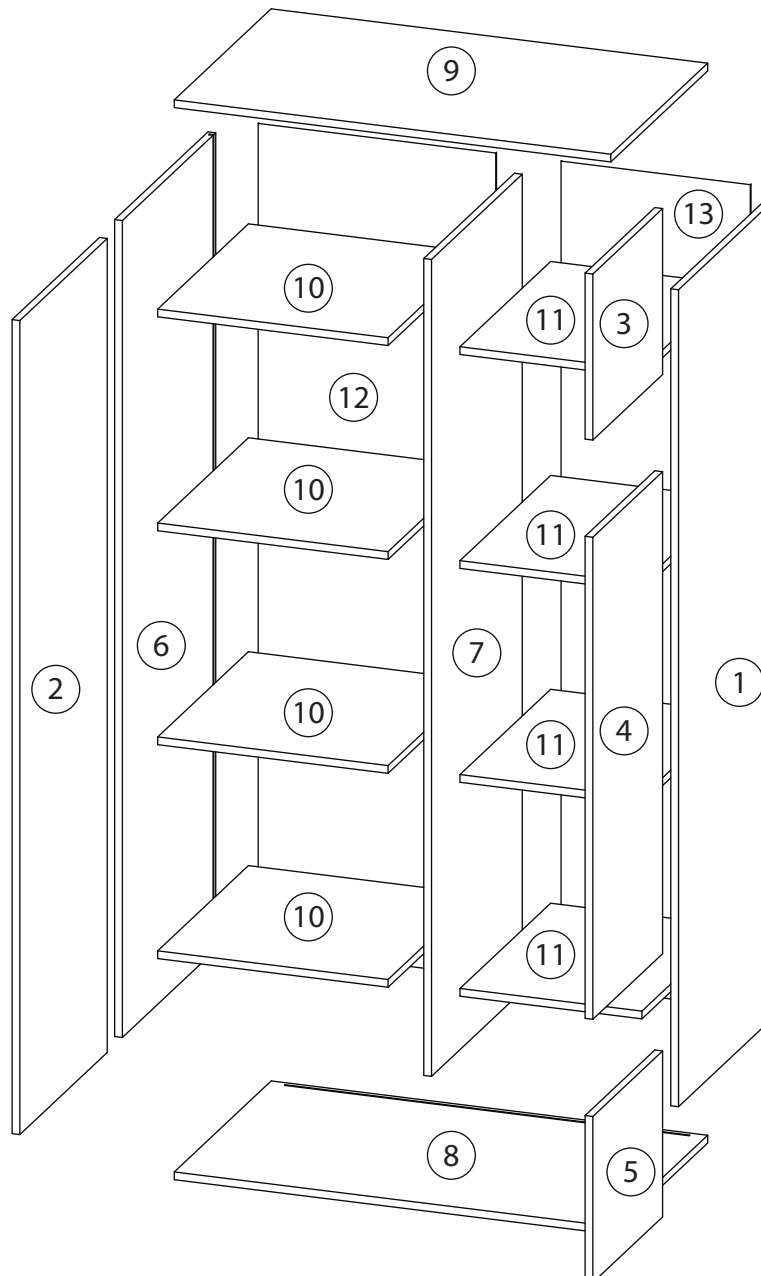

Детали

Поз.	Наименование	Кол-во	Длина	Ширина
1	Бок	1	530	1688
2	Дверь	1	496	1682
3	Дверь	1	396	343
4	Дверь	1	396	343
5	Дверь	1	396	996
6	Бок	1	1688	530
7	Вертикальная	1	1688	515
8	Дно	1	902	550
9	Крыша	1	902	550
10	Полка	4	476	515
11	Полка	4	376	515
12	Двп	1	1703	491
13	Двп	1	1703	391

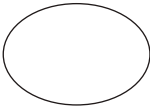
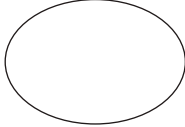
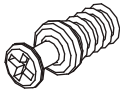
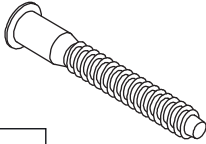
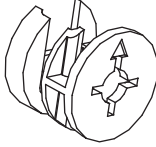

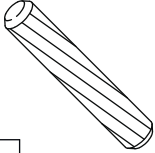
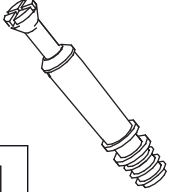
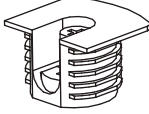
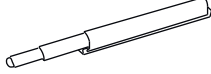
Фурнитура

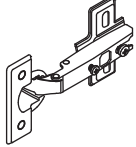
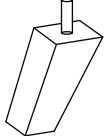
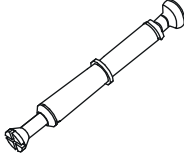
				
14	15	16	17	18
<u>Заглушка</u> <u>Ø13</u>	<u>Заглушка</u> <u>Ø17-20</u>	<u>Винт для стяжки</u> <u>VB35</u>	<u>Евровинт 7x50</u>	<u>Эксцентрик</u>
				
19	20	21	22	23
<u>Саморез 3,5x16</u>	<u>Шкант бук</u>	<u>Шток эксцентрика</u>	<u>Стяжка VB35</u>	<u>Упор-защелка</u> <u>с толкателем</u>
				
24	25	26	27	
<u>Евровинт 6,3x13</u>	<u>Петля накладная</u>	<u>Опора</u>	<u>Шток эксцентрика</u> <u>двухсторонний</u>	

1

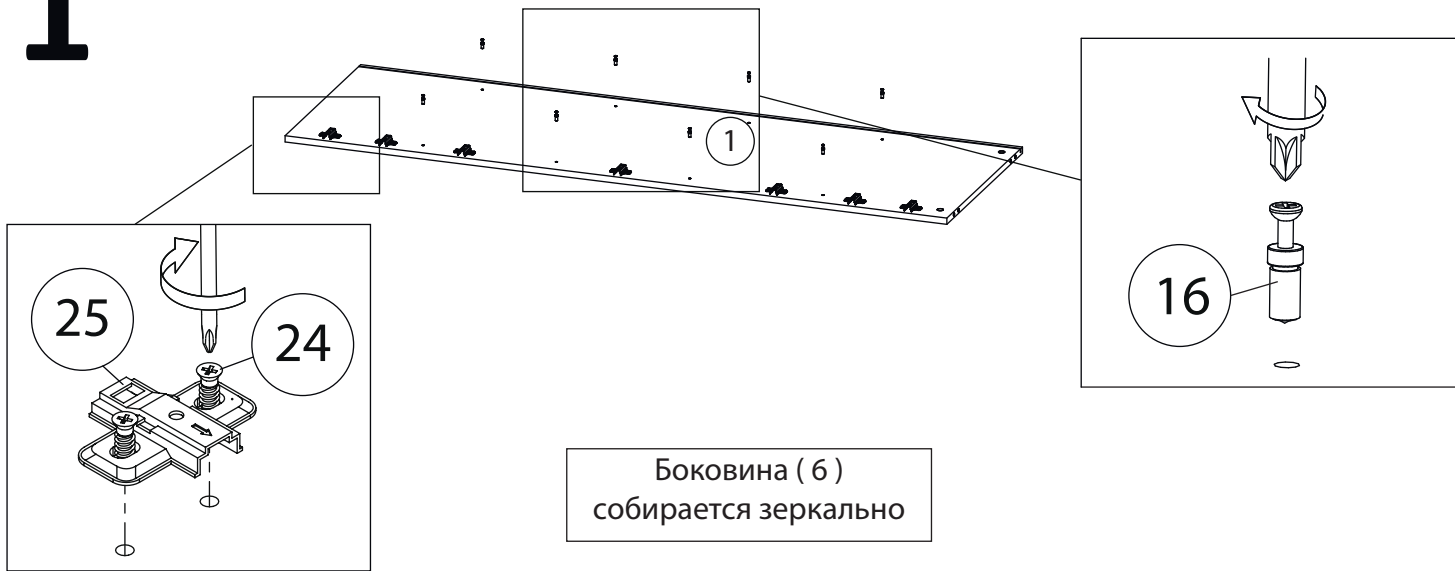

2

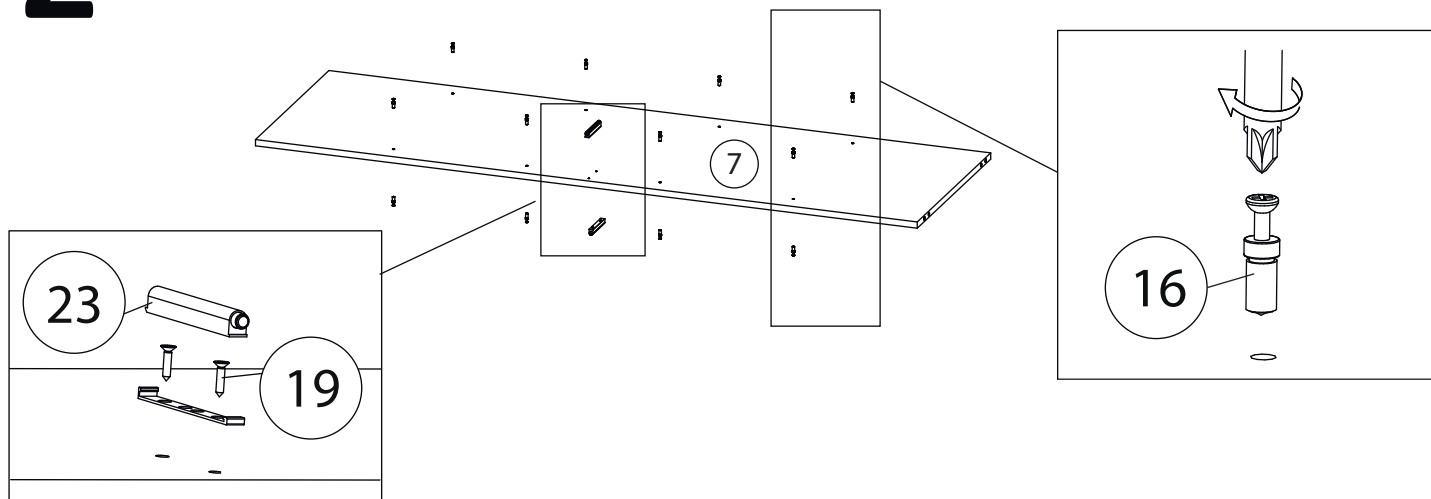

3

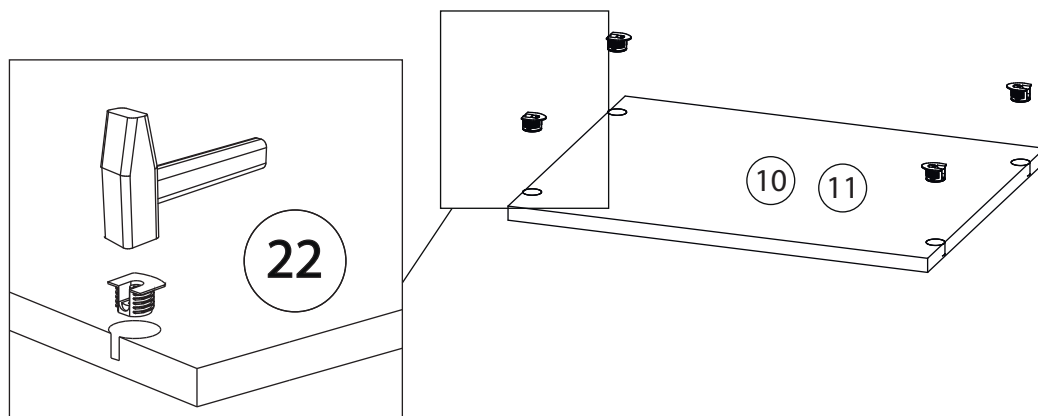

4

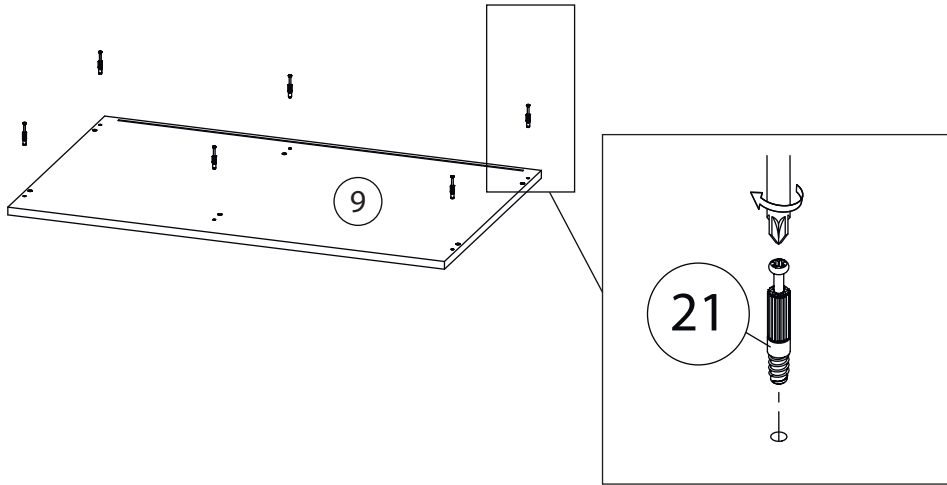

5

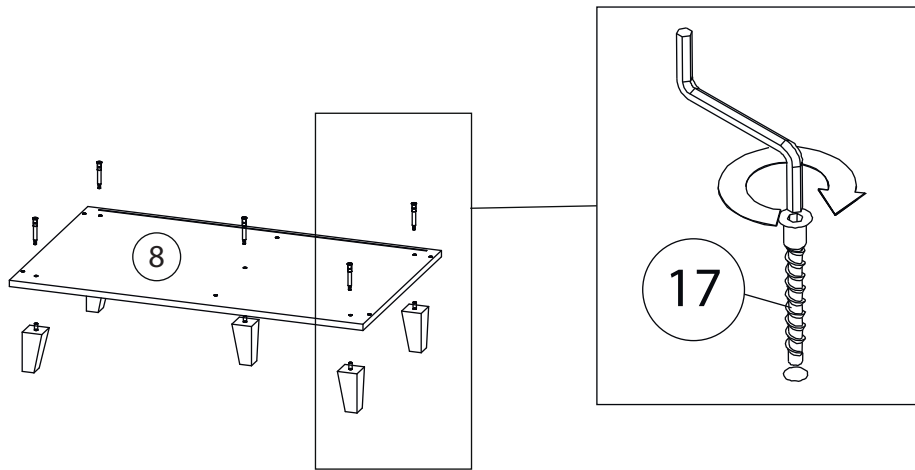

6

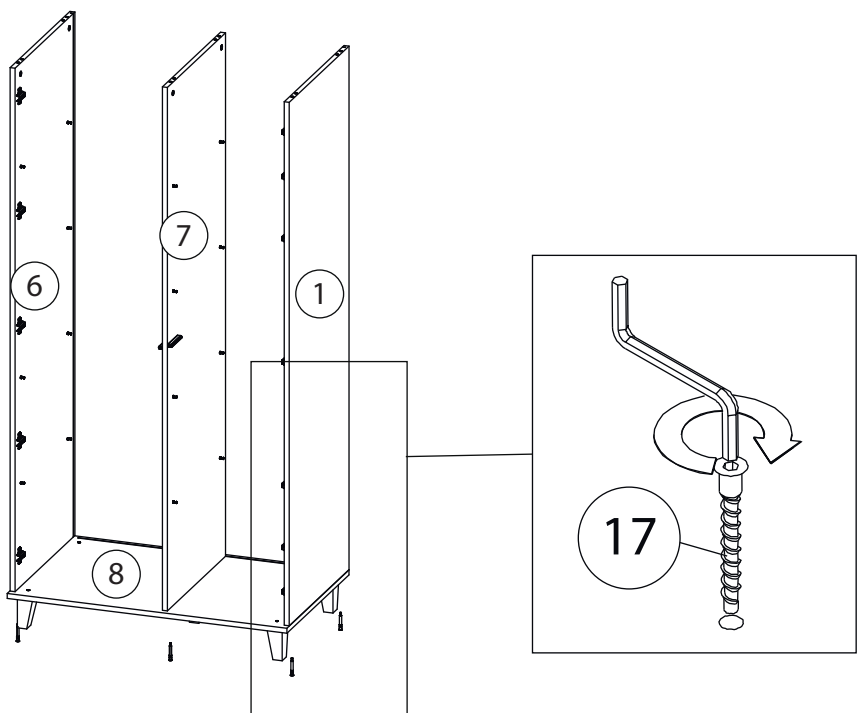

7

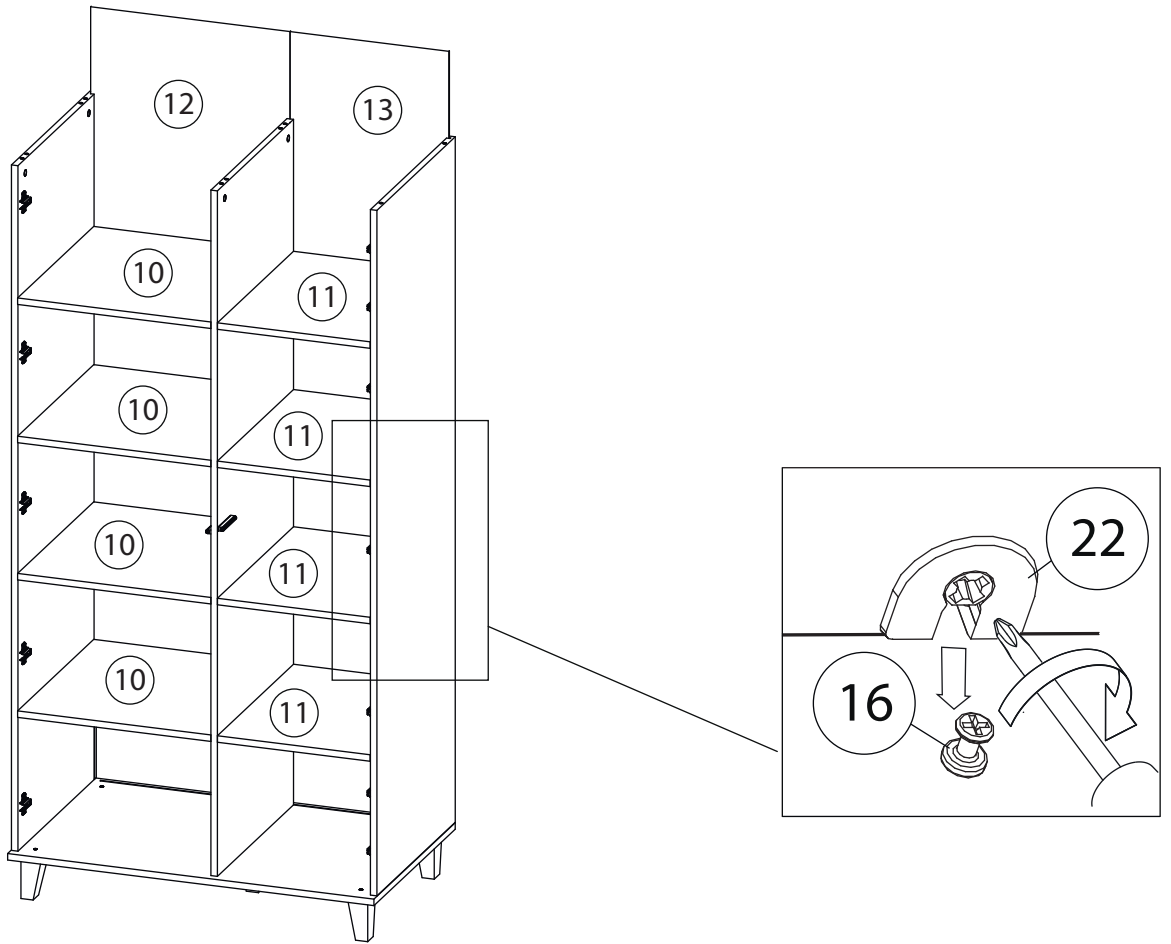

8

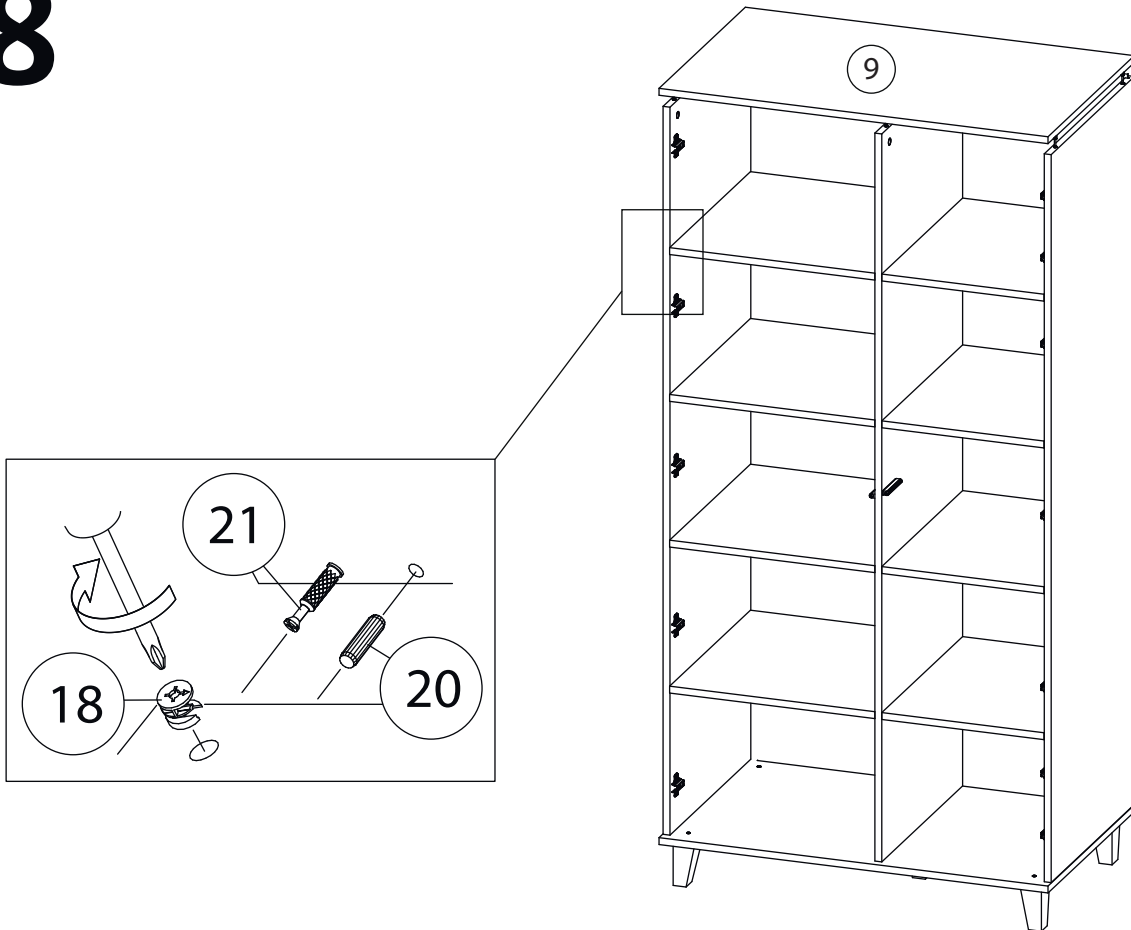

9

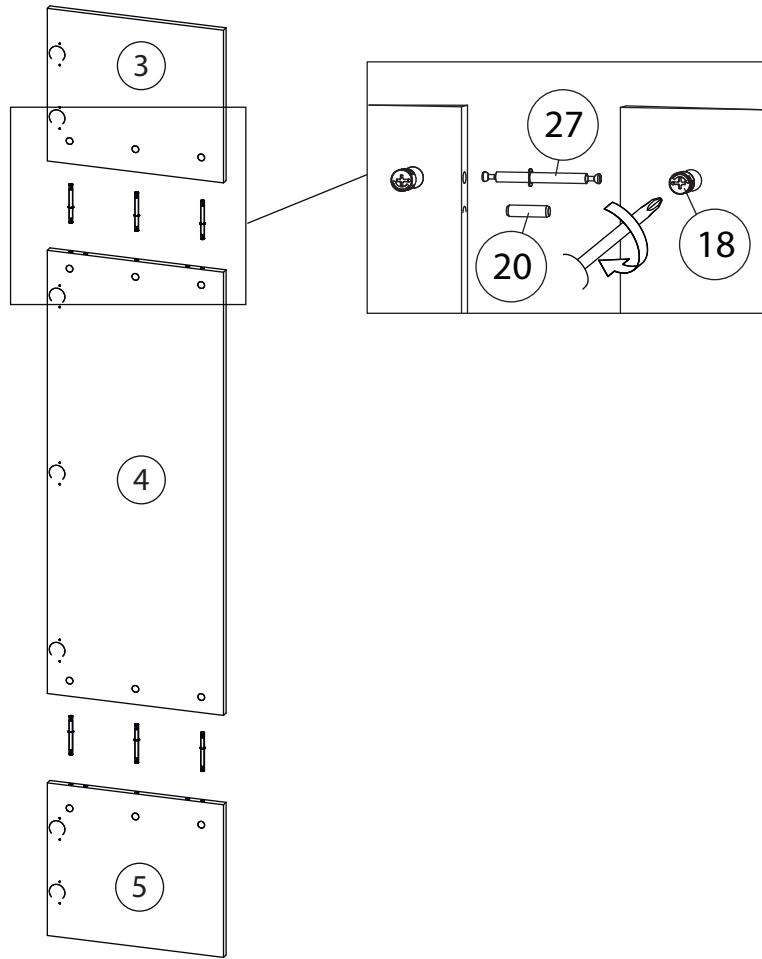

10

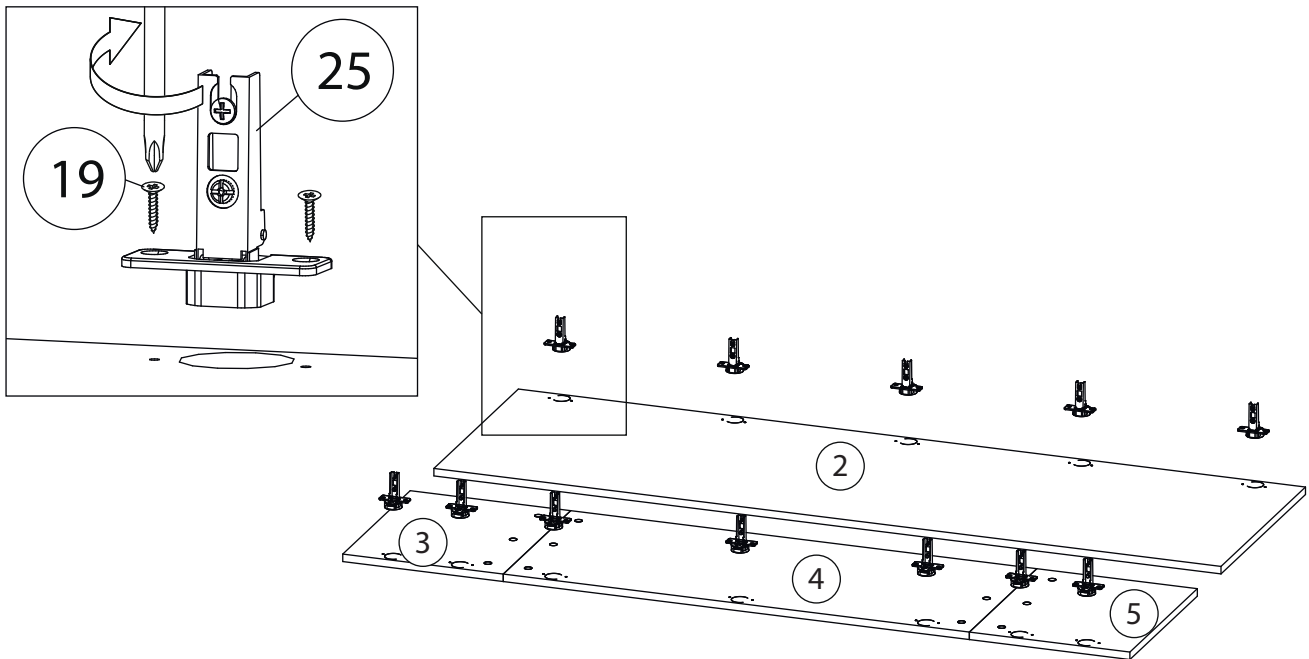

11

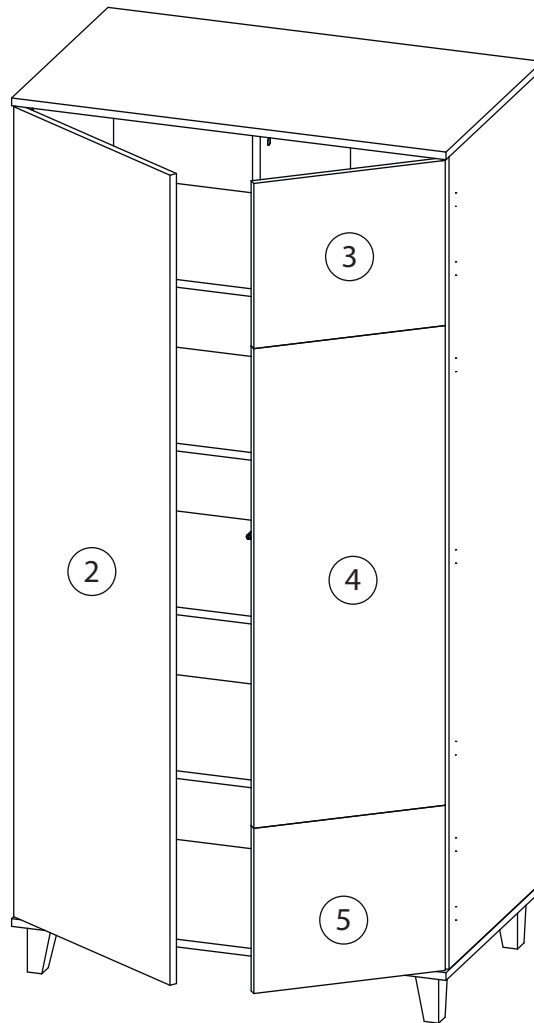
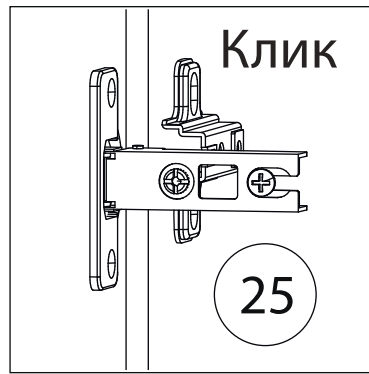

Заклеить технические отверстия заглушками.

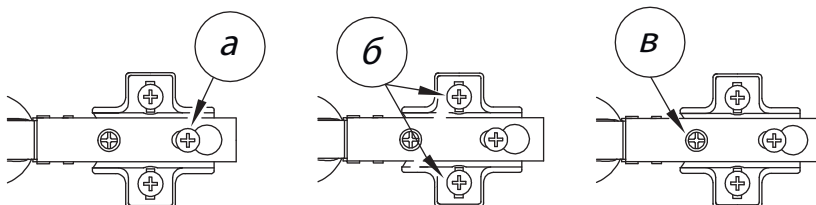

Регулировка петель

а - регулировка расстояния между дверью и корпусом
б - регулировка положения двери по-вертикали
в - регулировка положения ТТдвери по-горизонтали