

Инструкция по сборке

Альма - 13

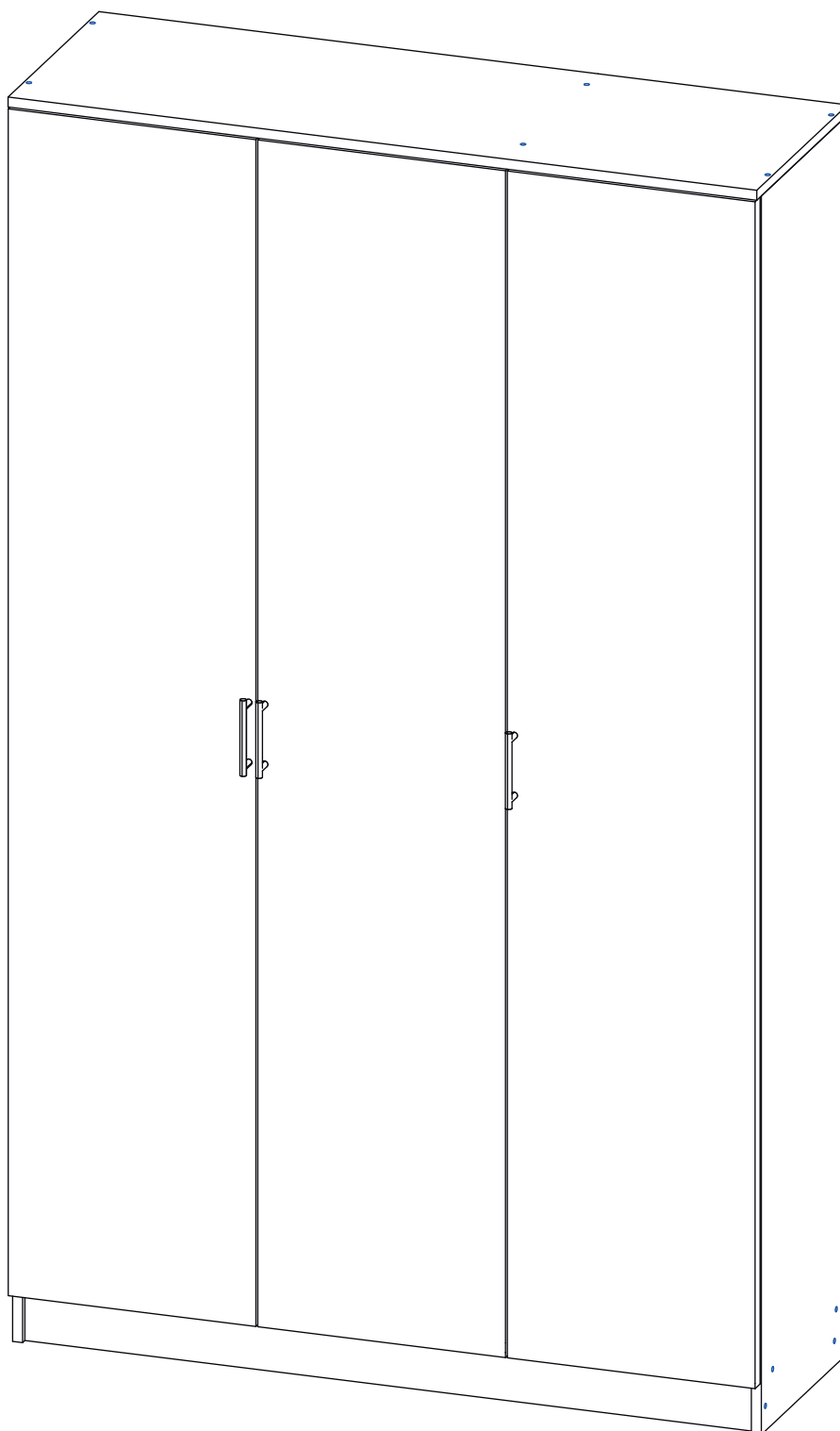



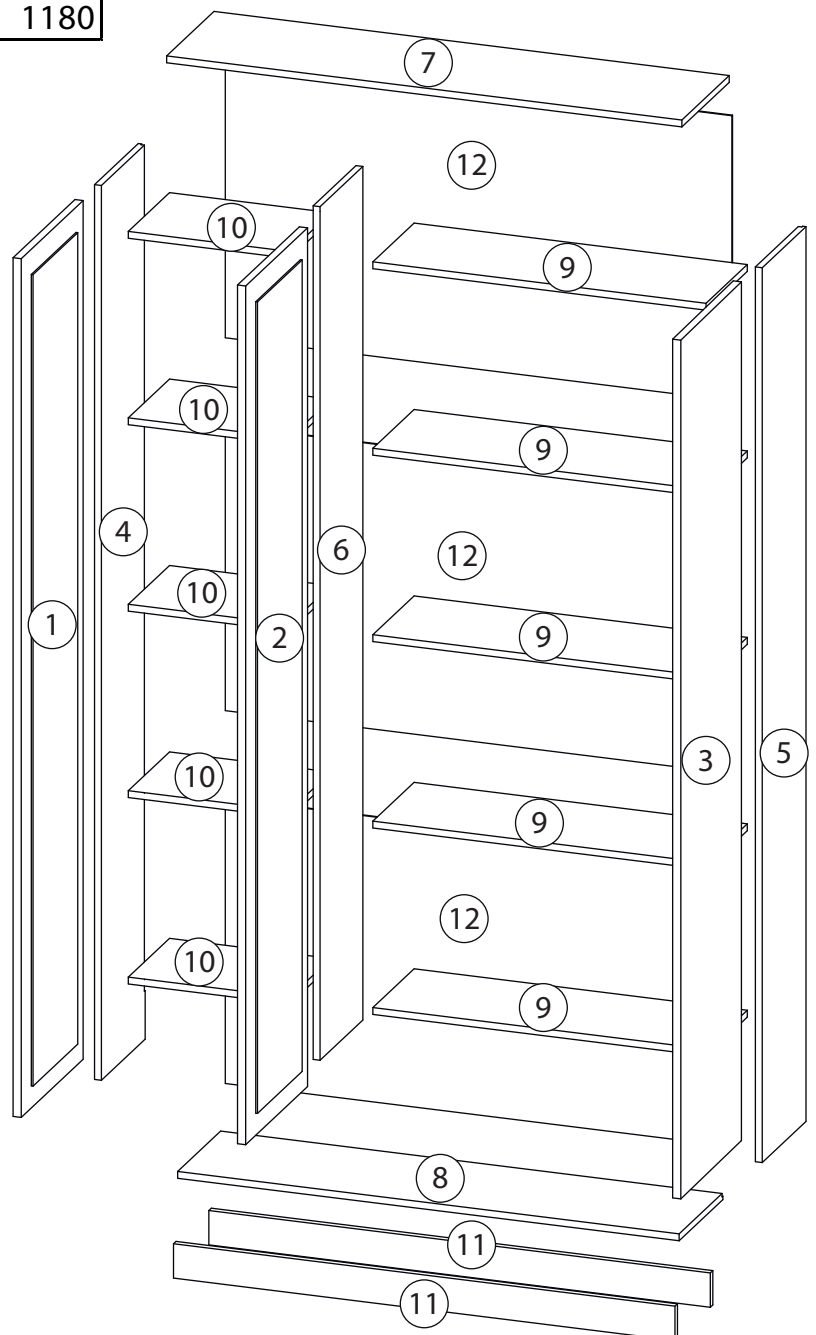

Детали

Поз.	Наименование	Кол-во	Длина	Ширина
1	Фасад	1	2000	396
2	Фасад	1	2000	396
3	Фасад	1	2000	396
4	Бок левый	1	2084	280
5	Бок правый	1 </td <td>2084</td> <td>280</td>	2084	280
6	Средник	1	1988	274
7	Крыша	1	1200	303
8	Дно	1	1168	280
9	Полка	5	776	264
10	Полка	5	376	264
11	Цоколь	2	1168	80
12	Задняя стенка	3	664	1180

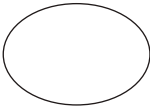
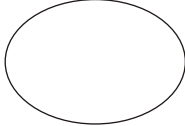

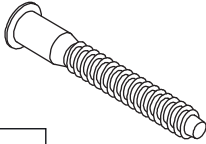
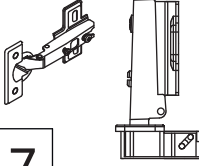
Фурнитура

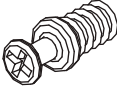
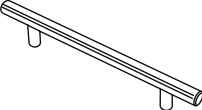
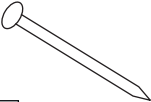
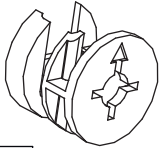
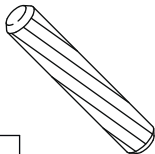
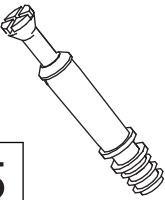
				
13	14	15	16	17
<u>Заглушка</u> <u>Ø13</u>	<u>Заглушка</u> <u>Ø17-20</u>	<u>Евровинт 6,3x13</u>	<u>Евровинт 7x50</u>	<u>Петля накладная</u>
				
18	19	20	21	22
<u>Саморез 3,5x16</u>	<u>Стяжка VB35</u>	<u>Винт для стяжки</u> <u>VB35</u>	<u>Ручка</u>	<u>Гвоздь 1,6x25</u>
				
23	24	25		
<u>Эксцентрик</u>	<u>Шкант бук</u>	<u>Шток эксцентрика</u>		

1

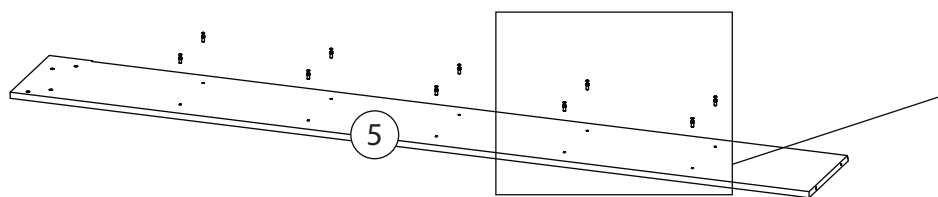

Бок левый (4), Средник (6)
собирается аналогично

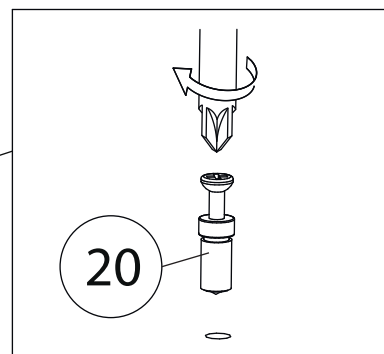

2

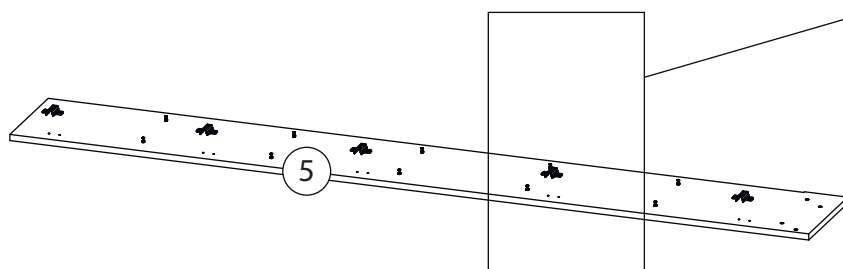

Бок левый (4), Средник (6)
собирается аналогично

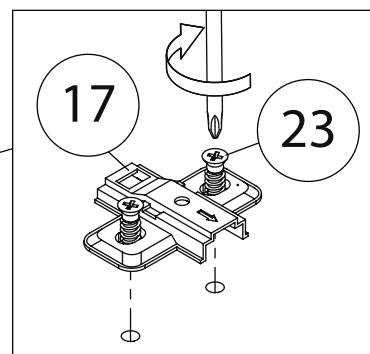

3

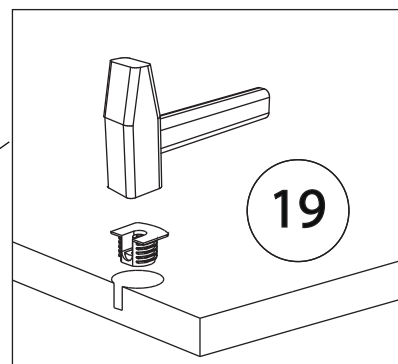
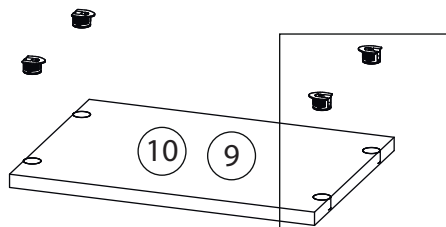

4

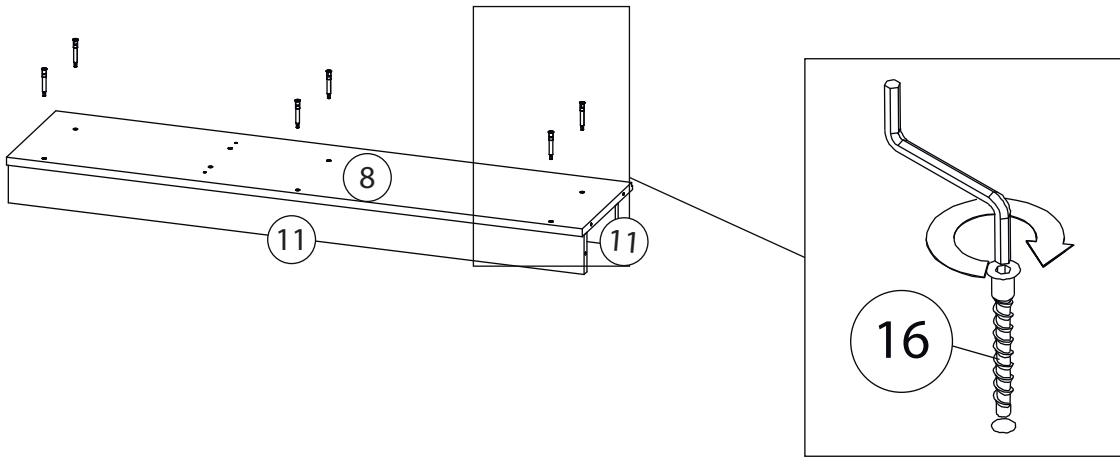

5

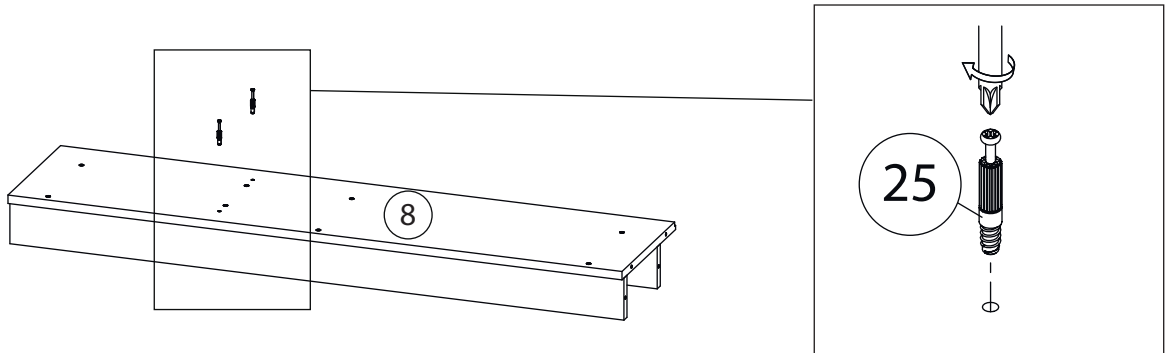

6

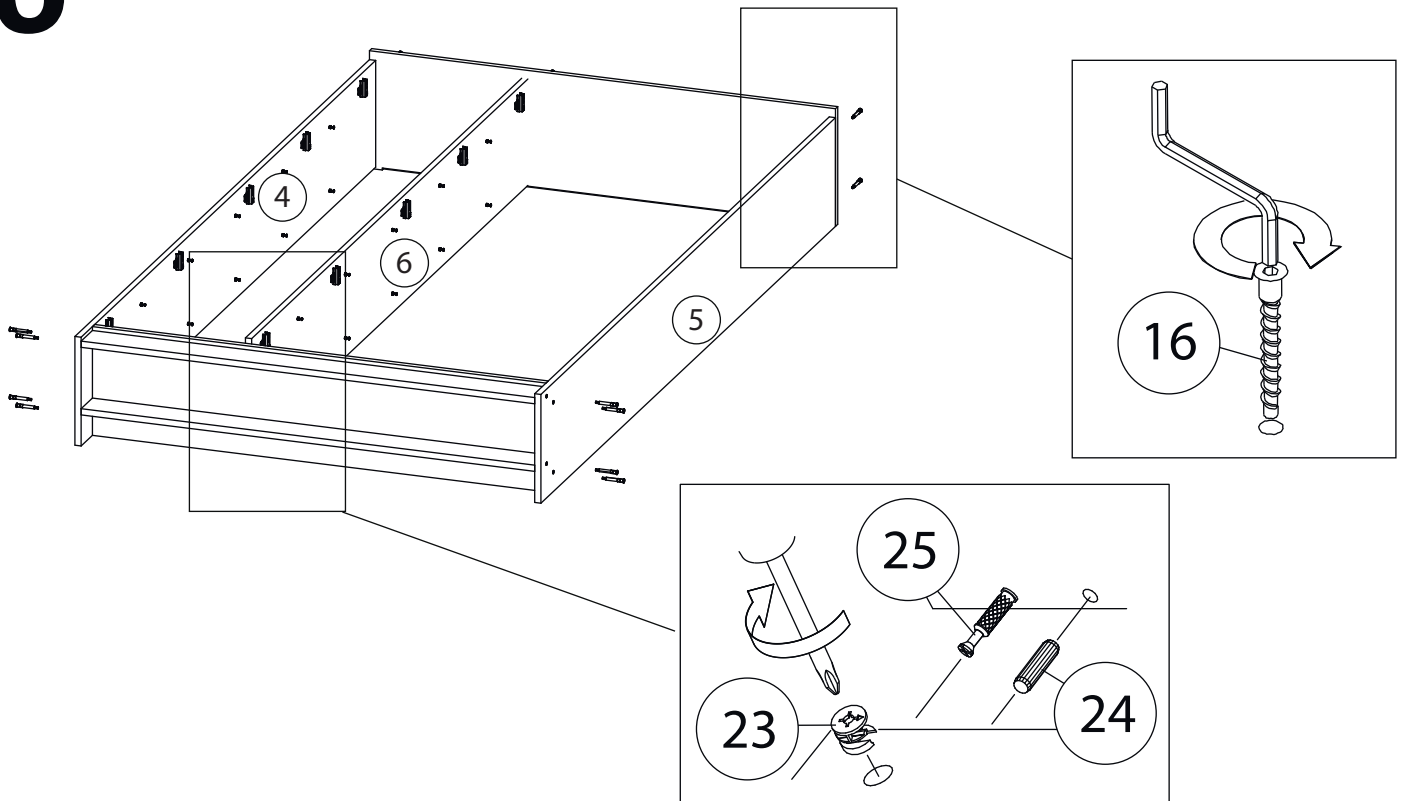

7

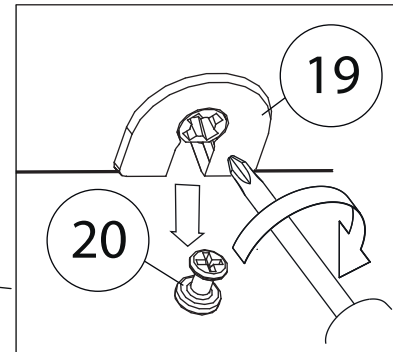
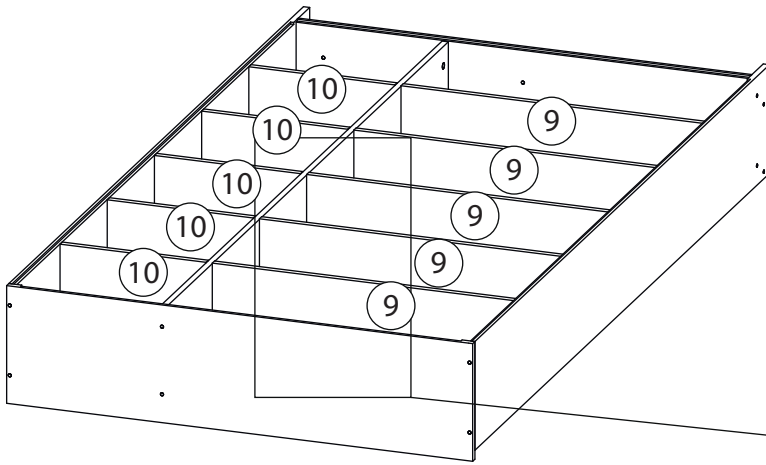

8

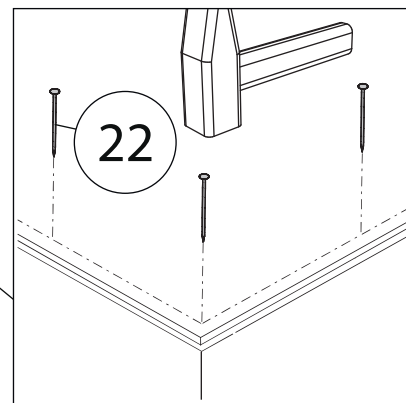
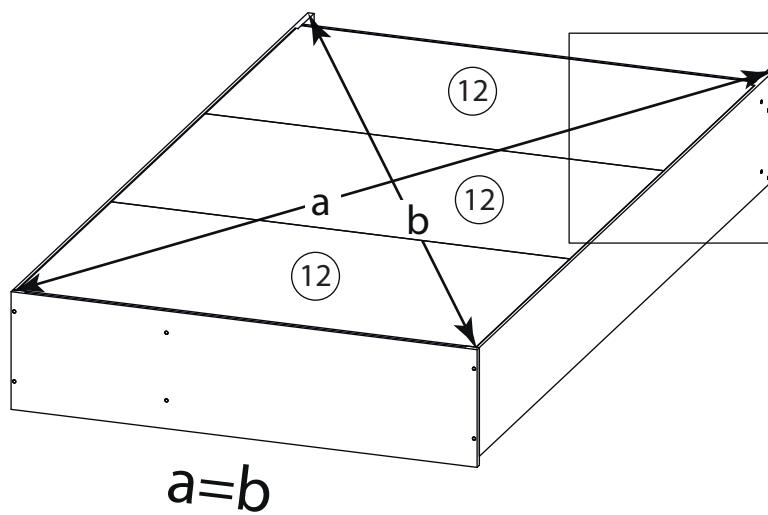

9

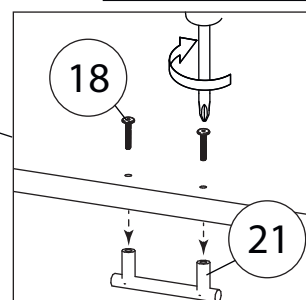
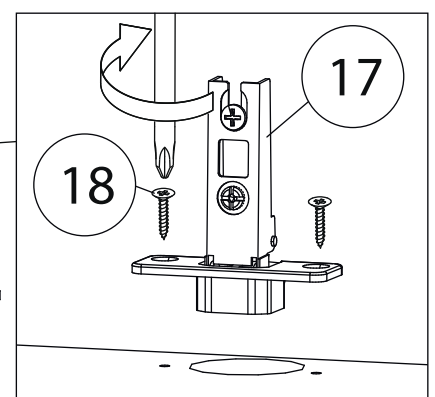
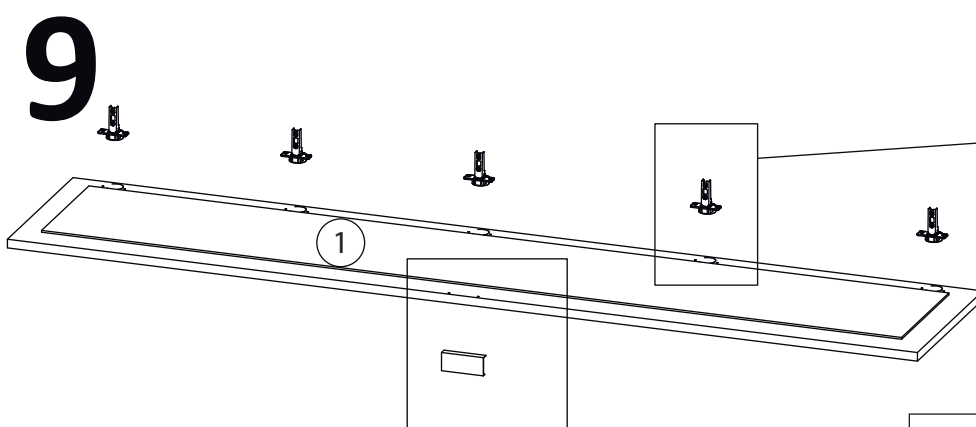

Фасад правый (2, 3)
собирается зеркально

10

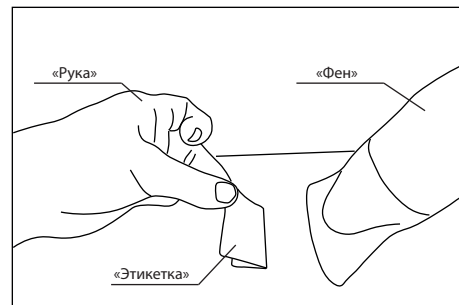
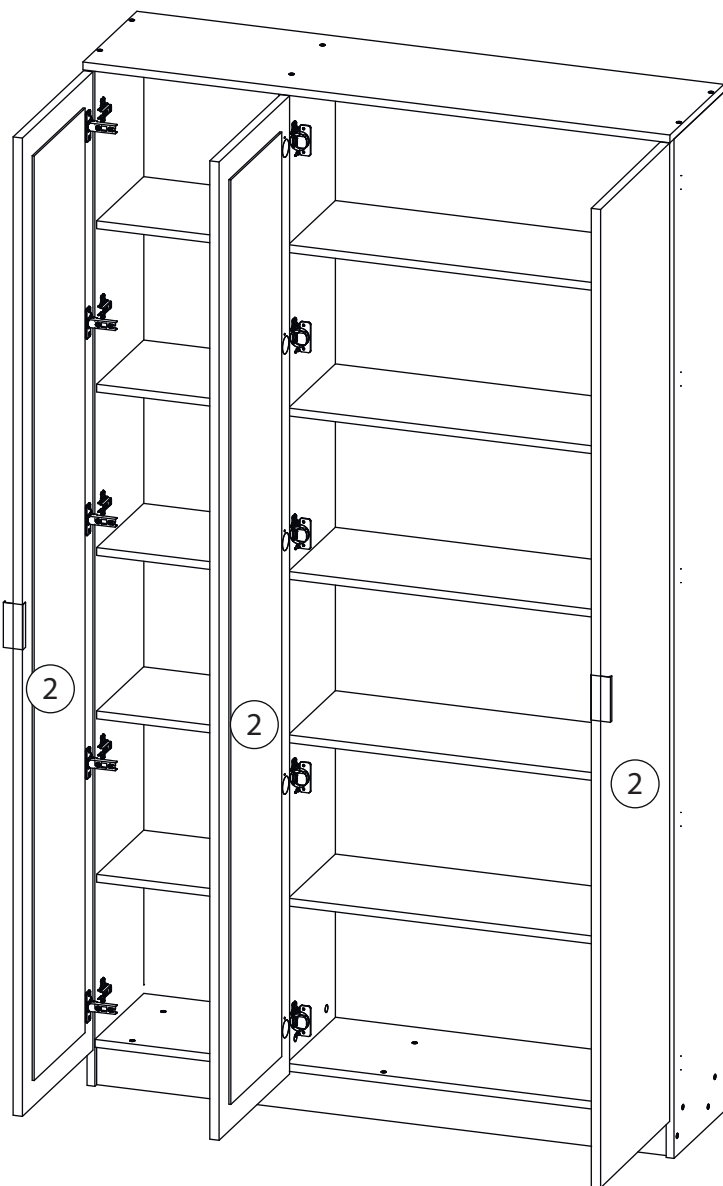

Удалить с детали этикетки со штрихкодом при помощи фена.



Заклеить технические отверстия заглушками.

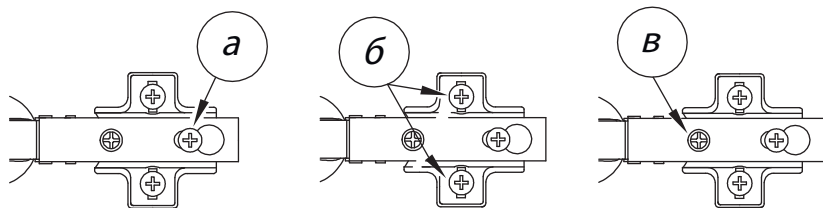

Регулировка петель

а - регулировка расстояния между дверью и корпусом
б - регулировка положения двери по-вертикали
в - регулировка положения ТТдвери по-горизонтали